

Installation Instructions and Use & Care Guide

Residential Gas Water Heater

Residential Direct Vented Gas Water Heater
with the Flammable Vapor Ignition Resistant Safety System
Not for use in Manufactured (Mobile) Homes

DO NOT RETURN THIS UNIT TO THE STORE



Read this manual and the labels on the water heater before you install, operate, or service it. If you have difficulty following the directions, or aren't sure you can safely and properly do any of this work yourself:

- Call your Local plumbing supplies store to have this water heater installed. Professional Installation is available for this product and the work is guaranteed.
- Schedule an appointment with a qualified person to install your water heater.
- Call our Technical Assistance Hotline which is listed on the water heater's warranty sheet. We can help you with installation, operations, troubleshooting, or maintenance. Before you call, write down the model and serial number from the water heater's data plate.

Incorrect installation, operation, or service can damage the water heater, your house and other property, and present risks including fire, scalding, electric shock, and explosion, causing serious injury or death.

Table of Contents

Important Safety Information.....	3
Getting Started	7
Installation.....	15
Operation	23
Troubleshooting	25
Maintenance	29
Repair Parts	33
Notes	35

WARNING: If the information in these instructions is not followed exactly, a fire or explosion may result causing property damage, personal injury or death.

Do not store or use gasoline or other flammable vapors and liquids in the vicinity of this or any other appliance.

WHAT TO DO IF YOU SMELL GAS

- **Do not try to light any appliance.**
- **Do not touch any electrical switch; do not use any phone in your building.**
- **Immediately call your gas supplier from a neighbor's phone. Follow the gas supplier's instructions.**
- **If you cannot reach your gas supplier, call the fire department.**

Installation and service must be performed by a qualified installer, service agency or the gas supplier.



LOW LEAD
CONTENT



Keep this manual in the pocket on heater for future reference whenever maintenance, adjustment or service is required.

Retain your original receipt as proof of purchase.

COMPLETED INSTALLATION (TYPICAL)

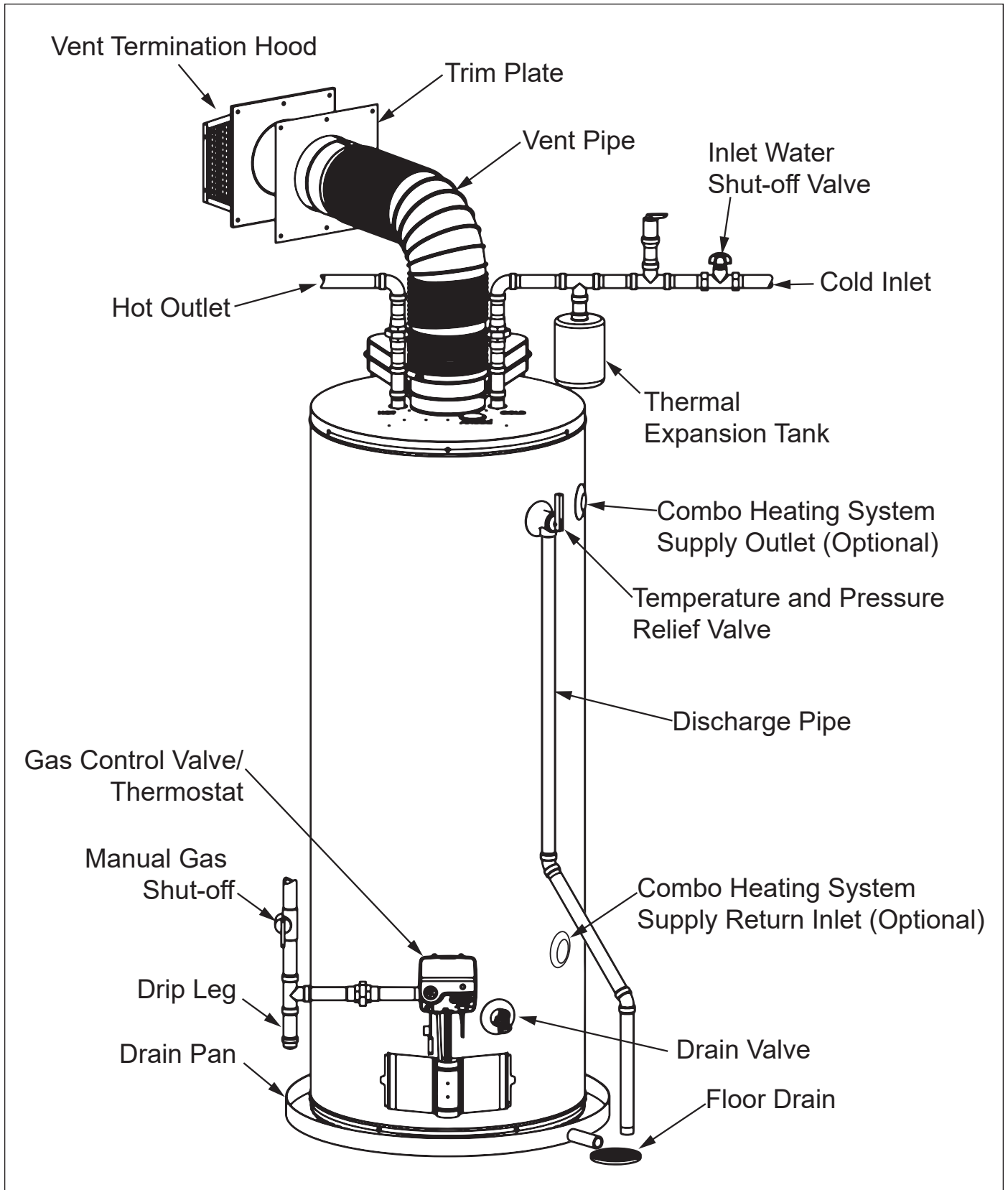

Note: If copper piping is used, then unions must be dielectric at inlet and outlet.

IMPORTANT SAFETY INFORMATION

To reduce the risk of property damage, serious injury or death, read and follow the precautions below, all labels on the water heater, and the safety messages and instructions throughout this manual.

RISKS DURING INSTALLATION AND MAINTENANCE



Lifting Risk

▲ WARNING! The water heater is heavy. Follow these

precautions to reduce the risk of property damage, injuries from lifting or impact injuries from dropping the water heater.

- Use at least two people to lift the water heater.
- Be sure you both have a good grip before lifting.
- Use an appliance dolly or hand truck to move the water heater.



Explosion Risk

▲ WARNING! Read the water heater's data

plate to determine the type of gas required. Failure to follow these instructions can result in serious injury or death from explosion, fire or carbon monoxide poisoning.

- Do not connect a natural gas water heater to an L.P. gas supply.
- Do not connect an L.P. gas water heater to a natural gas supply.
- Use a new CSA approved gas supply line.
- Install a shut-off valve on the gas supply line.

Gas Pressure

▲ WARNING! The gas supply pressure must not exceed the maximum supply pressure as stated on the water heater's data plate. The minimum supply pressure is for the purpose of input adjustment. L.P. gas supply pressure must not exceed 13" water column. Have a qualified person (licensed plumber, gas company personnel, or authorized service technician) check for proper L.P. gas pressure. L.P. gas pressures exceeding 13" water column can result in serious injury or death from explosion or fire.

RISKS DURING OPERATION

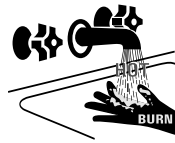

Scalding Risk

This water heater can make water hot enough to cause severe burns instantly, resulting in severe injury or death.

- Feel water before bathing or showering.
- To reduce the risk of scalding, install Thermostatic Mixing Valves (temperature limiting valves) at each point-of-use. These valves automatically mix hot and cold water to limit the temperature at the tap. Mixing valves are available at your local plumbing supplier. Follow the manufacturer's instructions for installation and adjustment of the valves.
- The gas control valve on this water heater has been factory set to its lowest setting to reduce the risk of scalding. Higher temperatures increase the risk of scalding, but even at 120°F, hot water can scald. If you choose a higher temperature setting, Thermostatic Mixing Valves located at each point-of-use are particularly important to help avoid scalding.

Table 1:

Temperature	Time to Produce a Serious Burn
120°F (49°C)	More than 5 minutes
125°F (52°C)	1-½ to 2 minutes
130°F (54°C)	About 30 seconds
135°F (57°C)	About 10 seconds
140°F (60°C)	Less than 5 seconds
145°F (63°C)	Less than 3 seconds
150°F (66°C)	About 1-½ seconds
155°F (68°C)	About 1 second

For more information about changing the factory temperature setting, refer to the "Adjusting the Temperature" section in this manual (page 24).

Even if you set the water heater's gas control valve to a low setting, higher water temperatures may occur in certain circumstances.

- In some cases, repeated small draws of water can cause the hot and cold water in the tank to "stack" in layers. If this happens, the water can be as much as thirty degrees hotter than the gas control valve setting. This temperature variation is the result of your usage pattern and is not a malfunction.
- Water temperature will be hotter if someone adjusted the gas control valve to a higher setting.
- Problems with the gas control valve or other malfunctions may result in higher than expected water temperatures.
- If the water heater is in a hot environment, the water in the tank can become as hot as the surrounding air, regardless of the temperature setting.
- If the water supplied to the water heater is pre-heated (by a solar heating system) the temperature in the tank may be higher than the water heater's temperature setting.

IMPORTANT SAFETY INFORMATION

- Should overheating occur or the burner fail to shut off, turn off the manual gas supply valve to the water heater and call a qualified person.

To reduce the risk of unusually hot water reaching the fixtures in the house, install Thermostatic Mixing Valves at each point-of-use.

If anyone in your home is at particular risk of scalding (for example, the elderly, children, or people with disabilities) or if there is a local code or state law requiring a certain water temperature at the hot water tap, these precautions are particularly important.

According to a national standard American Society of Sanitary Engineering (ASSE 1070) and most local plumbing codes, the water heater's thermostat should not be used as the sole means to regulate water temperature and avoid scalds.

Properly adjusted Thermostatic Mixing Valves installed at each point-of-use allow you to set the tank temperature to a higher setting without increasing the risk of scalds. A higher temperature setting allows the tank to provide much more hot water and can help provide proper water temperatures for appliances such as dishwashers and washing machines. Higher tank temperatures (140°F) also kill bacteria that cause a condition known as "smelly water" and can reduce the levels of bacteria that cause water-borne diseases.

Water Contamination Risk

Do not use chemicals that could contaminate the potable water supply. Do not use piping that has been treated with chromates, boiler seal, or other chemicals.



Fire Risk

This water heater is equipped with a Flammable Vapor Ignition Resistance (FVIR) system. FVIR is designed to reduce the risk of flammable vapor-related fires. FVIR makes this product more sensitive to installation errors or improper installation environments. The FVIR system will not prevent a possible fire/explosion if flammable vapors have accumulated in the combustion chamber and the water heater is lit.

Do not attempt to light this appliance by any means if you suspect flammable vapors have accumulated inside or outside the appliance. Immediately call a qualified person to inspect the appliance. Water heaters subjected to a flammable vapors incident will show a discoloration on the flame arrestor and require replacement of the entire water heater. Improper installation or an inadequate air supply can also cause the FVIR system to disable the water heater.

▲ WARNING! This water heater has a resettable thermal switch installed as part of the FVIR system. Do not attempt to disable or modify this feature in any way. Doing so can lead to fire, explosion or excessive and abnormal production of carbon monoxide.

To reduce the risk of a fire that could result in property damage, or serious injury or death:

- Do not store things that can burn easily such as paper or clothes next to the water heater.
- Do not store or use gasoline or other flammable substances in the vicinity of this or any other appliance.
- Keep the water heater from becoming wet. Immediately shut off the

water heater and have it inspected by a qualified person if you find that the wiring, gas control valve/thermostat or surrounding insulation have been exposed to water in any way (e.g., leaks from plumbing, leaks from the water heater itself can damage property and could cause a fire risk). If the water heater is subjected to flood conditions or the gas control valve/thermostat has been submerged in water, the entire water heater must be replaced.

- Replace the water heater's viewport if glass is missing or damaged. Repair the combustion chamber door seals if damaged.



Explosion Risk

High temperatures and pressures in the water heater tank can cause an explosion resulting in property damage, serious injury or death. A new Temperature and Pressure (T&P) Relief Valve is included with your water heater to reduce risk of explosion by discharging hot water. Additional temperature and pressure protective equipment may be required by local codes.

A nationally recognized testing laboratory maintains public inspection of the valve production process and certifies that it meets the requirements for Relief Valves for Hot Water Supply Systems, ANSI Z21.22. The T&P Relief Valve's relief pressure must not exceed the working pressure rating of the water heater as stated on the rating plate.

Maintain the T&P Relief Valve properly. Follow the maintenance instructions provided by the manufacturer of the T&P Relief Valve (label attached to T&P Relief Valve). If no label is attached to the T&P Relief Valve, follow the instructions in the T&P Relief Valve Maintenance section of this manual. An explosion could occur if the T&P Relief Valve

IMPORTANT SAFETY INFORMATION

or discharge pipe is blocked. Do not cap or plug the T&P Relief Valve or discharge pipe.

Fire and Explosion Risk if Hot Water is Not Used for Two Weeks or More.

▲ CAUTION! Hydrogen gas builds up in a hot water system when it is not used for a long period (two weeks or more). Hydrogen gas is extremely flammable. If the hot water system has not been used for two weeks or more, open a hot water faucet for several minutes at the kitchen sink before using any electrical appliances connected to the hot water system. If hydrogen is present there will probably be an unusual sound such as “air” escaping through the pipe as hot water begins to flow. Do not smoke or have an open flame or other ignition source near the faucet while it is open.

Carbon Monoxide Risk

▲ WARNING! This water heater operates by burning gas. Carbon monoxide is a colorless, odorless, gas that is a by-product of burning of fuels such as coal, wood, charcoal, oil, kerosene, propane, and natural gas. Breathing excessive and abnormal amounts of carbon monoxide can cause carbon



monoxide poisoning, resulting in serious injury or death. This water heater must be supplied with adequate combustion

air and must be properly vented to the outdoors. Have a qualified person (licensed plumber, authorized gas company personnel, or authorized service technician) install the venting system using these installation instructions. When the installation is complete, check the venting system using the instructions on page 23.

- Install a fuel gas and carbon monoxide detector in the living areas of your home.
- Do not install this water heater in a mobile home or manufactured housing.
- Failure to follow these instructions can result in serious injury or death from carbon monoxide poisoning.



Burn Risk

This water heater’s venting system can become hot enough to burn. Do not touch the venting system while water heater is on, or until the water heater is turned off and venting allowed to cool.

Before you start, be sure you have the following tools and supplies:

- Plumbing tools and supplies appropriate for the type of water pipes in your home.
- Thread sealant tape or pipe joint compound approved for potable water.
- For homes with copper pipes, you may purchase a Gas Water Heater Hook-Up Kit (available at your local plumbing supplier) with compression fittings that do not require soldering. This kit includes two 12” flex water lines, one 18” flexible gas line, two nipples, and thread sealant tape.
- For homes with plastic pipe, use threaded connectors suitable for the specific type of plastic pipe used: CPVC or PEX (cross-linked polyethylene). Do not use PVC pipe.
- Non-corrosive gas leak detection solution made from hand dishwashing soap mixed with water (1 part soap to 15 parts water) or children’s soap bubbles and a small, soft-bristled brush.

- An appliance dolly or hand truck to move the water heater.
- Safety gloves.

Recommended Accessories

- A metal drain pan.
- Automatic water leak detection and shut-off device.
- Pressure Reducing Valve.
- Thermal Expansion Tank.
- Thermostatic Mixing Valves at each point-of-use.
- Fuel gas and carbon monoxide detector.

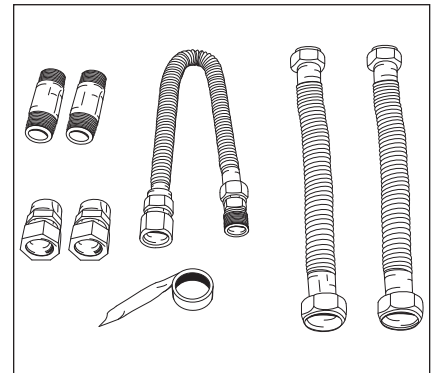

Figure 1 - Gas Water Heater Hook-Up Kit

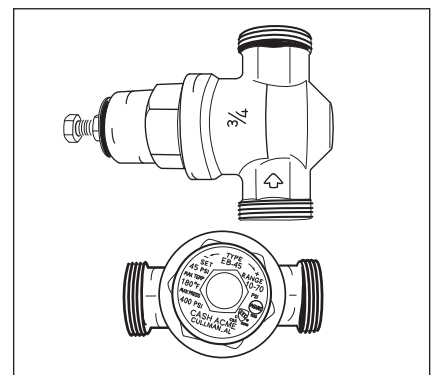

Figure 2 - Install a Pressure Reducing Valve set to 50 to 60 psi.

GETTING STARTED

1 Review all of the instructions before you begin work. Improper installation can damage the water heater, your home and other property, and can present risks of serious injury or death.

2 This water heater is a direct vented water heater which takes its combustion air from the outside of the structure and exhausts all products of combustion to the outside of the structure.

This water heater must be installed according to all local and state codes or, in the absence of local and state codes, the “National Fuel Gas Code”, ANSI Z223.1 (NFPA 54)-current edition. This is available from the following:

CSA America, Inc.
8501 East Pleasant Valley Road
Cleveland, OH 44131

National Fire Protection Association
1 Batterymarch Park
Quincy, MA 02269

Check with local code officials about codes governing this installation. Have your installation inspected by a code official to ensure the installation meets all local codes.

NOTICE: If you lack the necessary skills required to properly install this water heater, or you have difficulty following the instructions, you should not proceed but have a qualified person perform the installation of this water heater.

Massachusetts code requires this water heater to be installed in accordance with Massachusetts 248-CMR 2.00 and 248-CMR 5.00: State Plumbing Code. Other local and state authorities may have similar requirements or other codes applicable to the installation of this water heater.

Combustion and Ventilation Air Supply

▲ WARNING! This gas water heater requires an adequate source of clean air for combustion and ventilation. Without sufficient air, your water heater will have frequent pilot outages and may emit excessive and abnormal amounts of carbon monoxide.

Before beginning:

For safe operation an adequate supply of fresh, uncontaminated air must be provided for combustion.

This gas-fired water heater is a direct vent model. It connects directly to the outside of the building through the vent termination hood. The hood operates as both the combustion air intake and the heater exhaust port (see Figure 6).

All combustion air is obtained from outside the building through this hood. Ensure the area around the termination hood is always kept clear and that the air supply is not exposed to contamination or flammable vapors.

Be sure the vent piping is properly connected to prevent escape of dangerous flue gases which could cause deadly asphyxiation.

Obstructions and deteriorated vent systems may present serious health risk or asphyxiation.

Venting

▲ WARNING! Carbon Monoxide Hazard. This water heater must be supplied with adequate air and vented to outdoors. The vent system must be installed by a qualified person. Examples of a qualified person include gas technicians, authorized gas company personnel, and authorized service technicians. Failure to properly vent the water heater can result in severe injury or death from carbon monoxide poisoning.

To reduce the risk of carbon monoxide poisoning, install a fuel gas and carbon monoxide detector. Install and maintain the detector in accordance with the manufacturer’s instructions and local codes.

The vent system must be installed according to local and state codes, or in the absence of local or state codes, the “National Fuel Gas Code”, ANSI Z223.1 (NFPA 54)-current edition. Do not common vent this water heater with any gas appliance. Do not use a vent damper anywhere in the vent system of this water heater.

The vent system must terminate so that proper clearances are maintained as cited in local and state codes or the current edition of the “National Fuel Gas Code”, ANSI Z223.1 (NFPA 54)-current edition. See Figure 3 and Table 2 on the following page for more information.

GETTING STARTED

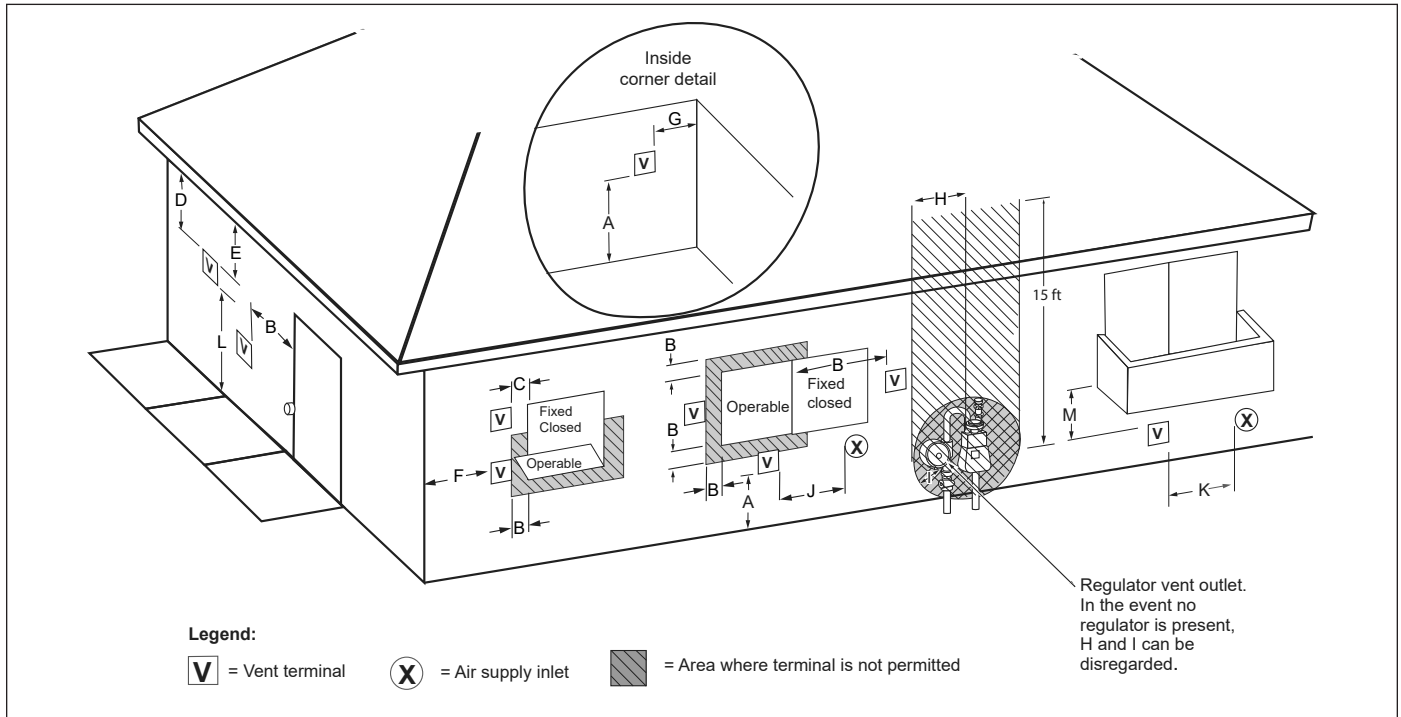

Figure 3 - Proper Vent Hood Termination Clearances for Direct Vent Heaters

Table 2: Minimum Direct Vent Termination Clearances

	Canada Installations ¹	US Installations ²	
A	Clearance above grade, veranda, porch, deck, or balcony	12 in (30 cm)	12 in
B	Clearance to window or door that may be opened	12 in (30 cm)	9 in
C	Clearance to permanently closed window	*	*
D	Vertical clearance to ventilated soffit located above the terminal within a horizontal distance of 2 ft (61 cm) from the center line of the terminal	12 in (30 cm)	12 in
E	Clearance to unventilated soffit	*	*
F	Clearance to outside corner	18 in (46 cm)	18 in
G	Clearance to inside corner	12 in (30 cm)	12 in
H	Clearance to each side of center line extended above meter/regulator assembly	3 ft (91 cm) within a height of 15 ft (4.6 m)	*
I	Clearance to service regulator vent outlet	3 ft (91 cm)	3 ft
J	Clearance to non-mechanical air supply inlet to a building or the combustion air inlet to any other appliance	12 in (30 cm)	9 in
K	Clearance to mechanical air supply inlet	6 ft (1.83 m)	3 ft above if within 10 ft horizontally
L	Clearance above paved sidewalk or paved driveway located on public property	7 ft (213 cm)**	*
M	Clearance under veranda, porch deck, or balcony	12 in (30 cm)***	12 in

*Clearance in accordance with local installation codes and the requirements of the gas supplier.

**A vent shall not terminate directly above a sidewalk or paved driveway that is located between two single family dwellings and serves both dwellings.

***Permitted only if veranda, porch, deck, or balcony is fully open on a minimum of two sides beneath the floor.

Notes:

- 1) In accordance with the current CSA B149.1, Natural Gas and Propane Installation Code
- 2) In accordance with the current ANSI Z223.1/NFPA 54, National Fuel Gas Code.
- 3) If locally adopted installation codes specify clearances different than those illustrated, then the most stringent clearance shall prevail.
- 4) Blocking air supply and exhaust vent by snow may cause incomplete combustion and an appliance failure. Install the termination by providing sufficient clearance from anticipated snow line in accordance with local code or manufacturer's instructions and make sure there is no blockage.
- 5) Provide an appropriate clearance between a vent termination and a building to prevent degradation to building materials caused by flue gases.

GETTING STARTED

Replacing a Water Heater Using the Existing Vent System

Read the “Installing a New Vent System” section of this manual and make sure your vent system is properly installed. Inspect the existing vent system for obstructions, corrosion, and proper installation. Repair or replace if necessary. The existing vent system must be UL listed and installed according to the vent manufacturer’s instructions and the terms of its listing. Do not use other materials such as dryer vent hose.

See Application A and B to determine if your new water heater can be retrofitted to an existing vent termination hood:

Vent Termination Hood (Application A)

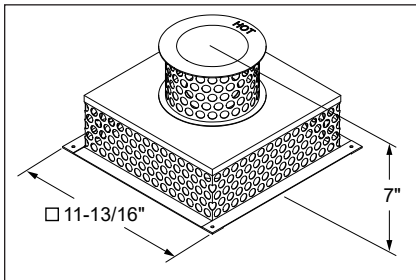

Figure 4 - American Vent Termination Hood (A)

A current American® DV water heater vent termination includes 3 inch inner piping to carry out the exhaust flue gases and 5 inch outer piping to carry in fresh combustion air.

If replacing a current American DV water heater, a duct reducer and union adapter must be installed to connect the existing vent termination hood to new inner and outer piping. Use kit number **100366535**.

IMPORTANT: A weather shroud is provided in kit number **100366535** and must be installed over the existing vent termination hood to ensure adequate protection from wind and other weather related hazards. Failure to do so may result in pilot outages at the water heater.

Vent Termination Hood (Application B)

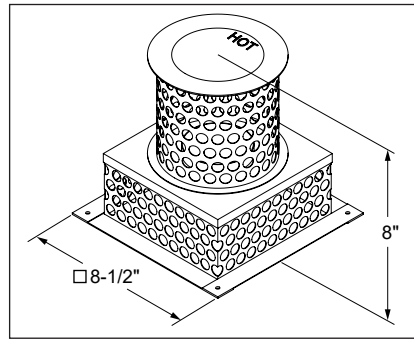

Figure 5 - Bradford White Vent Termination Hood (B)

A Bradford White® DV water heater vent termination includes 3 inch inner piping to carry out the exhaust flue gases and 5 inch outer piping to carry in fresh combustion air.

If replacing a Bradford White DV water heater, a duct reducer and union adapter must be installed to connect the existing vent termination hood to new inner and outer piping. Use kit number **100366536**.

If you are not sure the existing vent termination hood is compatible with your new water heater, call our Technical Assistance Hotline which is listed on the water heater’s warranty sheet.

Installing a New Vent System

This direct vent water heater uses a sealed venting system to supply fresh combustion air to the heater and to exhaust the products of combustion (flue gases) to the outdoors. The venting is a “pipe in a pipe” system. The inner (3”) piping carries out the exhaust flue gases while the outer (6”) piping carries in fresh combustion air. The corrugated end of the vent piping connects to the top of the water heater and the opposite end connects to the vent termination hood which will be mounted on the exterior wall. Figure 6 shows the hot exhaust gas exit and the location of the combustion air intake. Figure 14 through Figure 21 show how to assemble and connect the venting system.

Figure 11 through Figure 13 show various installation options.

DV Termination Hood

When the heater is in operation, the vent termination hood will be hot (see Figure 6).

Be sure venting is properly connected to prevent escape of dangerous flue gases which could cause deadly asphyxiation.

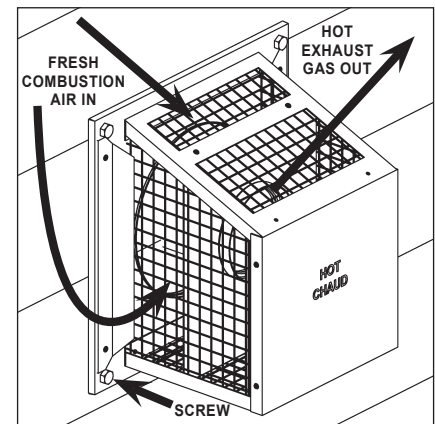

Figure 6 - Vent Termination Hood

GETTING STARTED

DV Termination Safety Cover

A Safety cover (see Figure 7) is available to prevent accidental contact with the vent terminal. Contact our Technical Assistance Hotline which is listed on the water heater's warranty sheet.

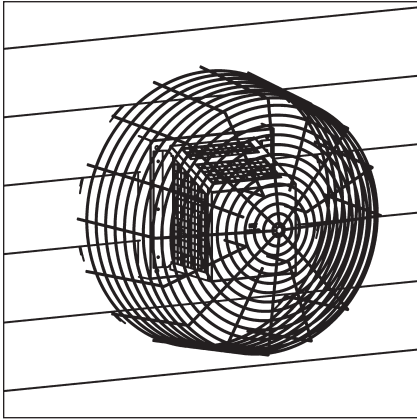

Figure 7 - Safety Cover

Alternatively, a wire mesh or louvered fencing guard can be built around the termination as shown in Figure 8.

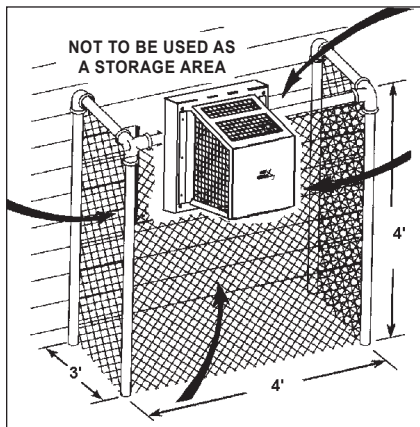

Figure 8 - Fencing Guard/Safety Cover

Confined Space Installations

This water heater connects to the vent termination hood using the sealed air intake and exhaust piping.

During operation this piping can become hot, especially in areas experiencing high ambient temperatures.

When installed in a confined space such as a closet, it is recommended that the confined space be ventilated to minimize the buildup of heat around the water heater. Figure 9 and Figure 10 show examples of ventilating a confined space.

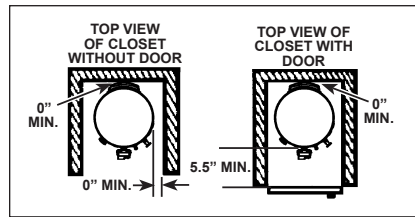

Figure 9 - Confined Space Clearances

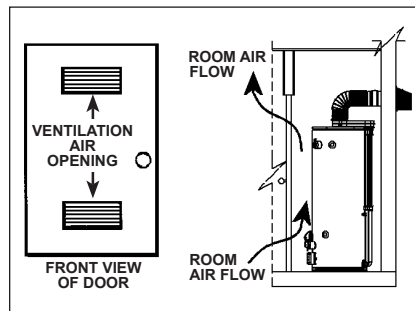

Figure 10 - Confined Space Ventilation

Clearances to Combustibles

Minimum clearances between water heater and combustibles is 0" at the sides and rear, 5-1/2" from the front and 12" from the top (see Figure 9). Minimum clearances from vent piping to combustibles is 1" except as noted in Figure 16. If clearances stated on the heater differ from these clearances, install water heater according to clearances stated on the heater.

Vent Connections

After the location for the vent terminal has been selected as outlined in Figure 3 and Figure 9, use the following instructions and illustrations for installation:

Locating Clearance Hole for Vent

Cut a clearance hole, approximately 7" in diameter, through the exterior wall for the vent assembly. The recommended height is 64" for 40 gallon models, 73" for 50 gallon models and 74" for 50 gallon Hi-Input models, as measured from the hole center to bottom of water heater. Where the wall is combustible and the wall thickness is over 14", a 1" clearance to combustible surfaces around the vent terminal is needed. The first 14" is zero clearance (see Figure 16 on page 12).

Standard Vent Arrangement

- If the horizontal length of the venting is less than 30" the restrictor plate must be installed (see Figure 11 through Figure 13 and Figure 17).
- Do not use the restrictor plate in an offset installation (see Figure 21).
- Do not use the restrictor plate if the horizontal length of the venting is greater than 30".

NOTICE: The length of "unstretched" corrugated tube could cause the length of the vent run to exceed the minimum. In this case cut off a piece of the corrugated tube to achieve the 17" minimum vent length.

GETTING STARTED

Vent Dimensions

Use Table 3 with Figure 11 - Figure 13.

Table 3: Vent Dimensions			
DIM.	4038	5040	5047
A	80" MAX.		
B	9" MIN.		
C (RECOMMEND)	63.63"	73.00"	74.00"
C (MINIMUM)	60.75	69.50	70.50"
D	14.25" MIN.		

NOTICE: Dimension "C" is the height above the floor to the center of the termination hole through the exterior wall.

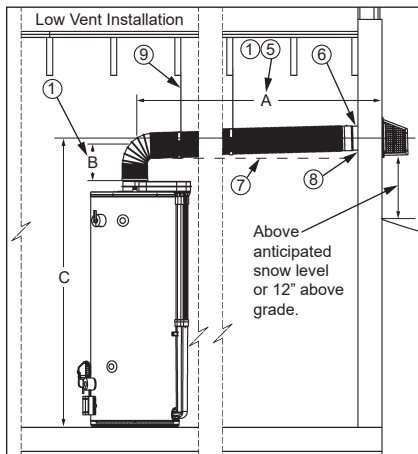

Figure 11 - Low Venting Installation

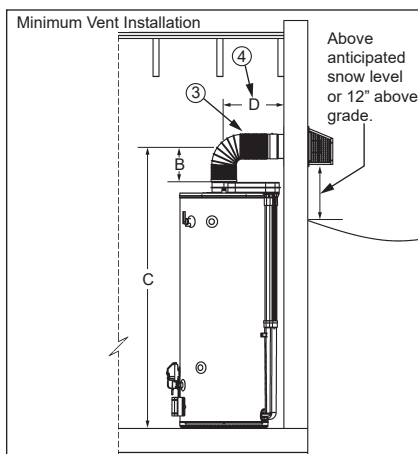

Figure 12 - Minimum Venting Termination

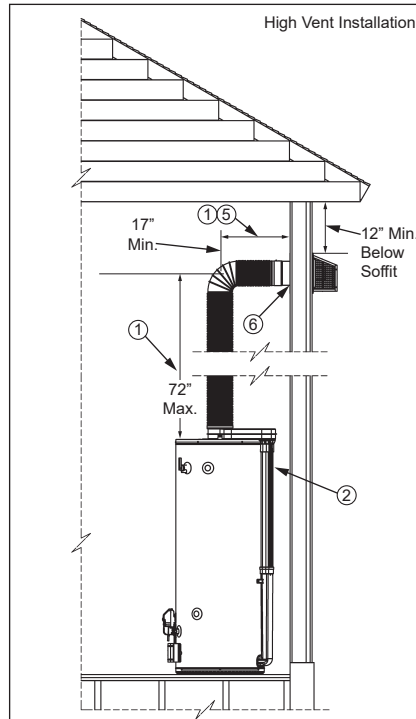

Figure 13 - High Venting Termination

NOTES: (applies to Figure 11 through Figure 13)

1. In any installation the total of dimension "A" plus dimension "B" must not exceed 89".
2. This heater can be installed with 0" clearance to a wall.
3. Minimum vent pipe clearance to combustibles is 1" (see Figure 16).
4. Minimum distance from center of heater to wall is 14.25".
5. Dimension "A" includes wall thickness.
6. Hole diameter in wall is 7".
7. Venting must slope up away from the heater a minimum of 0.25" per foot of length to prevent condensation from collecting and to provide sufficient draft.
8. Distance above horizontal at full extension is 2".
9. Use support stays to hold the venting to avoid sags or valleys.

Vent Assembly

The vent piping and the vent termination hood are to be connected as shown in Figure 15. Maintain vent clearances to combustibles as shown in Figure 16.

Depending on your access to where the vent termination passes through the wall, you may wish to connect the piping and vent termination hood together first. Inside the vent piping there are springs that hold the two corrugated pipes in position. When the pipes are stretched to the required length, the springs will remain properly spaced.

To connect the vent piping to the vent termination hood, first slide the inner (3") corrugated pipe over the inner vent termination pipe. Continue this action until the locking clip on the corrugated pipe snaps into position in the corresponding groove (see Figure 14). Secure corrugated pipe with screw (supplied) inserted through hole opposite the locking clip.

Repeat this process with the outer (6") corrugated pipe and lock it into position on the outer pipe on the vent termination (see Figure 14). Secure corrugated pipe with screw (supplied) inserted through hole opposite the locking clip.

NOTICE: To reduce the friction between the corrugated pipe and the O-rings, it is recommended to dampen the O-rings with water.

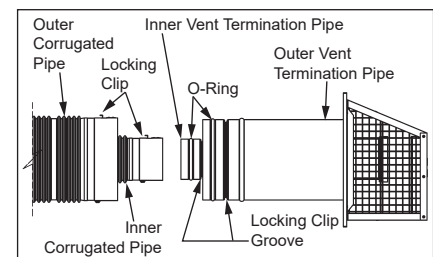

Figure 14 - Vent Piping

GETTING STARTED

The completed connection is shown in Figure 15.

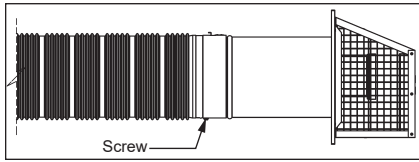

Figure 15 - Completed Vent Connection

Securing Vent Termination Assembly to the Exterior Wall

Some models are supplied with trim plates which may be used to cover the holes in the wall (see “Completed Installation” on page 2 and Figure 16). Slide one trim plate (if supplied) over the outer corrugated tube, then insert the outer corrugated tube through the clearance hole from exterior wall. Secure the trim plate to the exterior wall, then secure the vent terminal to the exterior wall with 4 screw anchors (included) appropriate for the type of wall construction. Caulk the junction of the vent terminal base plate and the exterior wall with exterior type sealant (not included). Slide the trim plate (inside) over the outer corrugated tube and fasten the trim plate to the interior wall. Caulk the junction of the outer corrugated tube and the trim plate (inside) with suitable sealant. The vent termination hood attaches to the vent piping as shown in Figure 15.

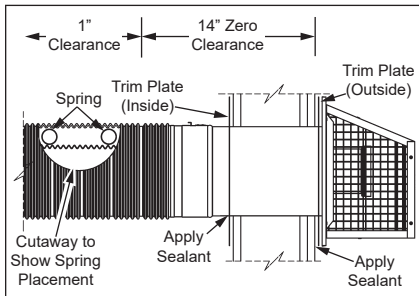

Figure 16 - Trim Plate Install

Vent Restrictor Plate

The vent restrictor plate (see Figure 17) is required for short horizontal runs on low vent installations (Figure 11) and high vent installations (Figure 13).

For short horizontal vent runs (see Figure 12) place the restrictor plate over the flue tube reducer before connecting the inner corrugated tube to the flue tube reducer. **DO NOT** use the restrictor plate if the horizontal run is greater than 30”.

For high vertical runs use the restrictor plate only when the vertical run of the venting above the heater is greater than 48” (see Figure 13).

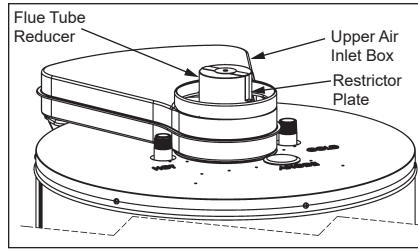

Figure 17 - Restrictor Plate

Uncompressing the Corrugated Tubing

- Pull the inner corrugated tube towards the water heater and leave some length over the water heater’s center for bending (see Figure 18).
- Pull the outer corrugated tube toward the water heater and leave it 2” shorter than the inner corrugated tube.
- Make sure there are two springs evenly spaced at the bend in the tube.
- Use metal hangers spaced a maximum of 36” apart to keep venting level or with a slope upward from the heater to terminal. It is recommended to add vibration isolation between the venting and hangers to prevent vibration and noise from spreading to the rest of the building.

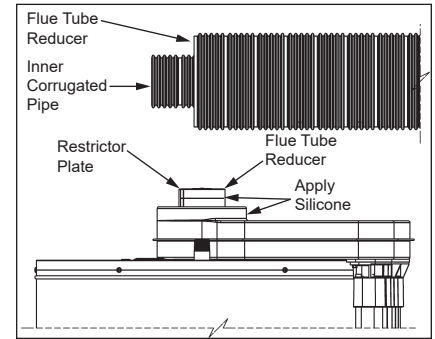

Figure 18 - Uncompressing the Corrugated Tubing

Vent Connection to the Water Heater

Bend both the corrugated pipes toward the flue connection on the water heater. Pull and connect the inner corrugated pipe to the water heater’s flue tube reducer with hi-temp red silicone (included) and gear clamp. Make sure this connection is tight and leak proof (see Figure 18 and Figure 19).

IMPORTANT: The sealant between the inner corrugated pipe and water heater’s flue tube reducer must be hi-temp red silicone or other material suitable for 600°F continuous service.

NOTICE: If you are using the vent restrictor plate, the inner vent pipe is to go over the side legs and down the stops.

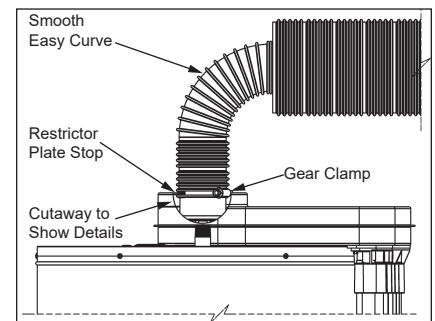

Figure 19 - Vent Connection to the Water Heater

Apply hi-temp red silicone (included) around the collar on air manifold box. Pull the outer corrugated pipe all the

GETTING STARTED

way on to collar and secure with the gear clamp. Pull the free end of the corrugated pipe past the gear clamp and secure with one sheet metal screw (see Figure 20).

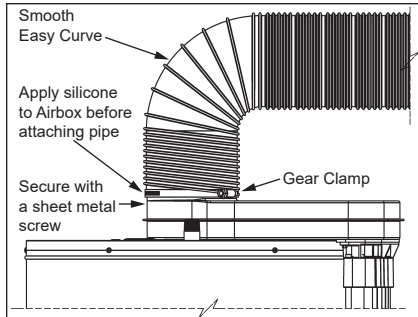

Figure 20 - Apply Silicone to the Venting

Offset Vent Arrangement

Where a straight vent arrangement is impossible, a horizontal 90° maximum bend can be made. Use the water heater casing outer diameter as a template to form the corrugated tube.

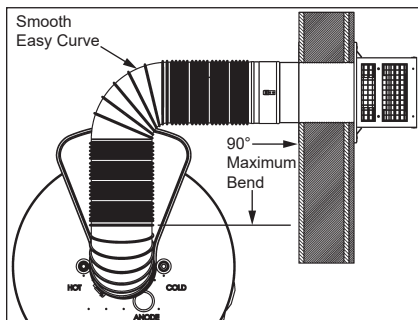

Figure 21 - Venting Alignment (Top View)

NOTICE: To ensure good exhaust gas flow, bend vent piping using a smooth, easy curve as shown in Figure 19 through Figure 21. Do not use reverse or compound curves as shown in Figure 22.

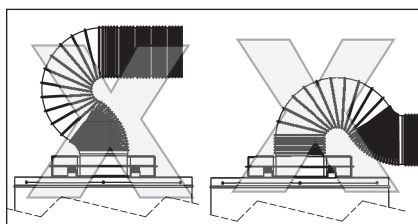

Figure 22 - Bad Venting Configurations

Gas Piping

Gas piping must be installed according to local and state codes or, in the absence of local and state codes, the “National Fuel Gas Code”, ANSI Z223.1 (NFPA 54)-current edition.

NOTICE: When installing gas piping, apply pipe joint compound or thread sealant tape approved for fuel gases.

1. Install a readily accessible manual shut-off valve in the gas supply line as recommended by the local utility. Know the location of this valve and how to turn off the gas to this unit.
2. Install a Sediment Trap as shown in the Gas Piping figure below. The Sediment Trap must be no less than three inches long for the accumulation of dirt, foreign material, and water droplets.
3. Install a ground joint union between the gas control valve and the manual gas shut-off valve. This is to allow easy removal of the gas control valve.

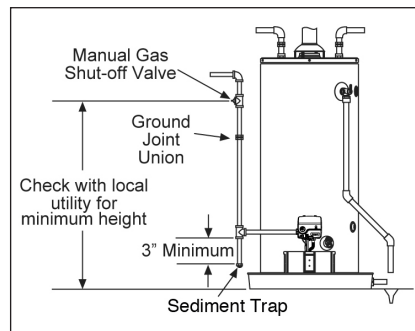

Figure 23 - Gas Piping

4. Turn the gas supply on and check for leaks. Use a small, soft-bristled brush to apply a hand dishwashing soap and water mixture (1 part soap to 15 parts water) or children’s soap bubbles to all connection points of the gas piping. Saturate all the connections and check for gas leaks (which will appear as small bubbles). If any leaks are detected, tighten the appropriate connection(s) and re-check.

Gas Pressure

NOTICE: When testing gas pipes with a test pressure of more than ½ psi, disconnect the gas line at the manual shut-off valve and cap the gas line. Do not subject the water heater’s gas control valve or manual shut-off valve to more than ½ psi pressure for any reason. If you are pressure testing the gas line with test pressure of ½ psi or less, you may isolate the water heater from the gas line by closing the manual shut-off valve.

High Altitude Installations

▲ WARNING! High altitude orifice must be installed for operation above 7,700 feet.

Installations above 7,700’ require replacement of the burner orifice in accordance with the current edition of the “National Fuel Gas Code” (ANSI Z223.1/NFPA 54). Failure to replace the orifice could result in improper and inefficient operation of the appliance, producing carbon monoxide gas in excess of safe limits, which could result in serious personal injury or death. Contact your gas supplier for any specific changes which may be required in your area.

GETTING STARTED

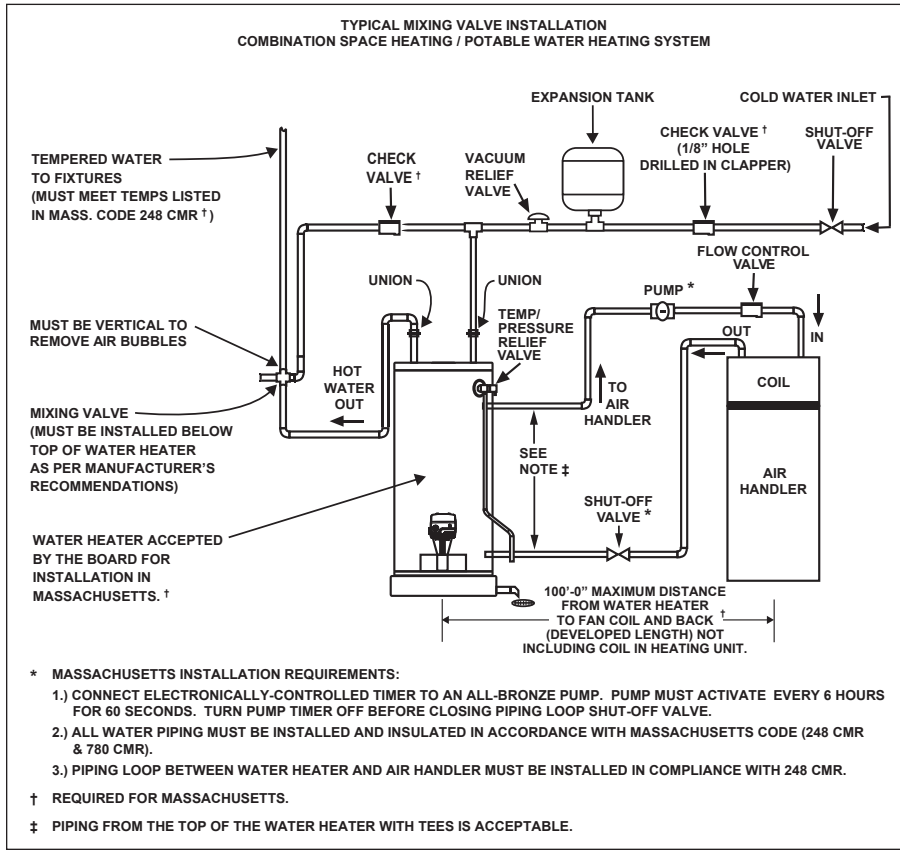

Figure 24 - Combustion Space Heating and Potable Water (Typical Installation)

Space Heating

Some water heater models are equipped with inlet/outlet side connections for use with space heating applications. If this water heater is to be used to supply both space heating and domestic potable (drinking) water, the instructions listed below must be followed:

- This water heater is suitable for combination water (potable) heating and space heating and not suitable for space heating applications only. The side connections may not be used as the primary water inlet and outlet connections. If the heater is to be operated without using the side connections, these openings **MUST** be closed with the two plugs supplied with the heater.

- Be sure to follow the manual(s) shipped with the air handler system.
- This water heater is not to be used as a replacement for an existing boiler installation.
- Do not use with piping that has been treated with chromates, boiler seal or other chemicals and do not add any chemicals to the water heating piping.
- If the space heating system requires water temperatures in excess of 120°F, install a Thermostatic Mixing Valve in the domestic (potable) hot water supply at each point-of-use to limit the risk of scald injury. Install the mixing valve per its manufacturer's instructions.

- Pumps, valves, piping, and fittings must be compatible with potable water.
- A properly installed flow control valve is required to prevent thermosiphoning. Thermosiphoning is the result of a continuous flow of water through the air handler circuit during the off cycle.
- The domestic hot water line from the water heater should be vertical past any mixing valve or supply line to the air handler to remove air bubbles from the system. Otherwise, these bubbles will be trapped in the air handler heat exchanger coil, reducing efficiency.
- Do not connect the water heater to any system or components previously used with non-potable water heating appliances when used to supply potable water.

Solar Installation

If this water heater is used as a solar storage heater or as a backup for the solar water heating system, the water supply temperatures to the water heater tank may be in excess of 120°F. A Thermostatic Mixing Valve or other temperature limiting valve must be installed in the water supply line to limit the supply temperature to 120°F. The unit must be set to Standard Mode (see the "Operating Modes" section on page 24).

NOTICE: Solar water heating systems can often supply water with temperatures exceeding 180°F and may result in water heater malfunction.

INSTALLATION

Step: 1

✓ Verify that Your Home is Equipped and Up-To-Date for Proper Operation

Installing a new water heater is the perfect time to examine your home's plumbing system and make sure the system is up to current code standards. There have likely been plumbing code changes since the old water heater was installed. We recommend installing the following accessories and any other needed changes to bring your home up to the latest code requirements. Updating your plumbing system can help extend the life of your water heater, avoid damage to your home and property, and reduce the risk of serious injuries or death. Inspect your home and install any devices you need to comply with current codes and assure that your new water heater performs at its best. Check with your local plumbing official for more information.

✓ Water Pressure

Most codes allow a maximum incoming water pressure of 80 psi (we recommend a working pressure no higher than 50-60 psi). Check your home's water pressure gauge and adjust if necessary. High water pressure can damage the water heater, piping, and other appliances.

HOW: Purchase an inexpensive water pressure gauge available at your local plumbing supplier. Connect the water pressure gauge to an outside faucet and measure the maximum water pressure experienced throughout a 24-hour period (highest water pressures often occur at night).

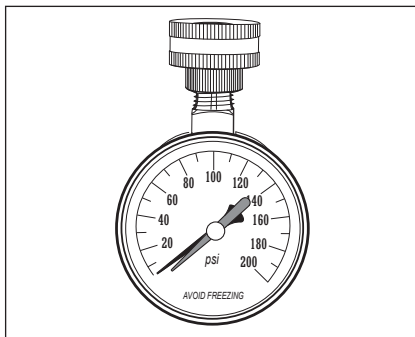

Figure 25 - Use a Water Pressure Gauge to make sure your home's water pressure is not too high.

To adjust your home's water pressure: Locate your home's Pressure Reducing Valve (PRV) on the main incoming (cold) water supply line and adjust the water pressure control to between 50 and 60 psi. If your home does not have a Pressure Reducing Valve, install a PRV on the home's main water supply line and set it to between 50 and 60 psi. Pressure Reducing Valves are available at your local plumbing supplier.

BACKGROUND: Over the years, many utilities have increased water supply pressures so they can serve more homes. In some homes today, pressures can exceed 100 psi. High water pressures can damage water heaters, causing premature leaks. If you have replaced toilet valves, had a water leak, or had to repair appliances connected to the plumbing system, pay particular attention to your home's water pressure. When purchasing a PRV, make sure the PRV has a built-in bypass.

✓ Water Pressure Increase Caused by Thermal Expansion

Verify that you have a properly sized Thermal Expansion Tank. We recommend installing an expansion tank if your home does not have one. Plumbing codes require a properly

pressurized, properly sized Thermal Expansion Tank in almost all homes.

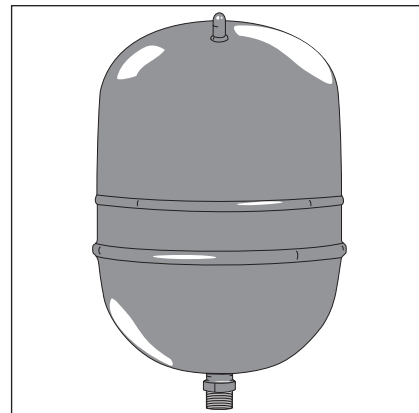

Figure 26 - A Thermal Expansion Tank helps protect the home's plumbing system from pressure spikes.

HOW: Connect the Thermal Expansion Tank (available at your local plumbing supplier) to the cold water supply line near the water heater. The expansion tank contains a bladder and an air charge. To work properly, the Thermal Expansion Tank must be sized according to the water heater's tank capacity and pressurized to match the home's incoming water pressure. Refer to the instructions provided with the Thermal Expansion Tank for installation details.

BACKGROUND: Water expands when heated, and the increased volume of water must have a place to go, or thermal expansion will cause large increases in water pressure (despite the use of a Pressure Reducing Valve in the home's main water supply line). The Safe Drinking Water Act of 1974 requires the use of backflow preventers and check valves to restrict water from your home reentering the public water system. Backflow preventers are often installed in water meters and may not be readily visible. As a result, most all plumbing systems today are now "closed," and almost all homes now need a Thermal Expansion Tank.

INSTALLATION

A Thermal Expansion Tank is a practical and inexpensive way to help avoid damage to the water heater, washing machine, dishwasher, ice maker, and even toilet valves. If your toilet occasionally runs for no apparent reason (usually briefly at night), that may be due to thermal expansion increasing the water pressure temporarily.

NOTICE: Expansion tanks are pre-charged with a minimum of 12 psi air charge. The expansion tank's air pressure must be adjusted to match the inlet pressure of your home but must not be higher than 80 psi.

Water Pipe and Tank Leaks

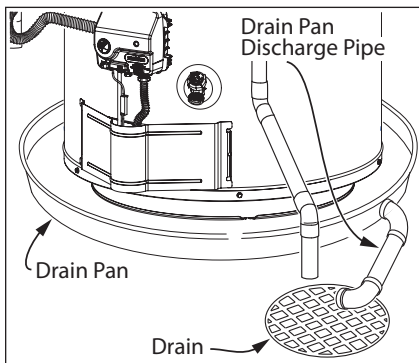

Figure 27 - A metal drain pan piped to an adequate drain can help protect flooring from leaks and drips.

Leaks from plumbing pipes or from the water heater itself can damage property and could cause a fire risk.

- Install an automatic leak detection and shut-off device (available at your local plumbing supplier). These devices can detect water leaks and can shut off the water heater's water supply if a leak occurs.
- Install a metal drain pan (available at your local plumbing supplier) under the water heater to catch condensation or leaks from the piping connections or tank. Most codes require, and we recommend, installing the water heater in a metal drain

pan that is piped to an adequate drain. The drain pan must be at least 2 inches wider than the diameter of the water heater. Install the drain pan so the water level would be limited to a maximum depth of 1-3/4". The pan must not restrict air flow to the burner.

Water Temperature Regulation

Install Thermostatic Mixing Valves to regulate the temperature of the water supplied to each point-of-use (for example, kitchen sink, bathroom sink, bath, shower). Install and adjust the mixing valve according to its manufacturer's instructions.

WARNING! Even if the water heater's thermostat is set to a relatively low temperature, hot water can scald. Install Thermostatic Mixing Valves at each point-of-use to reduce the risk of scalding (see Table 1).

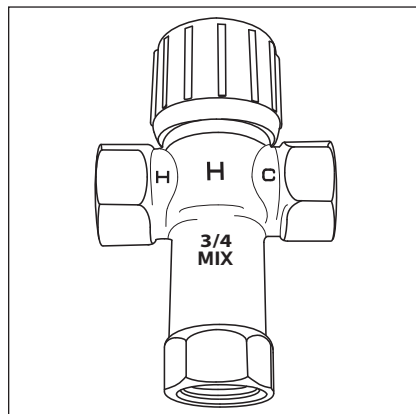

Figure 28 - Thermostatic Mixing Valves installed at each point-of-use can help avoid scalding.

BACKGROUND: A Thermostatic Mixing Valve, installed at each point-of-use, mixes hot water from the water heater with cold water to more precisely regulate the temperature of hot water supplied to fixtures. If you are not sure if your plumbing system is equipped with properly installed and adjusted Thermostatic Mixing Valves at each point where hot water is used, contact a qualified person.

Step: 2

Verify that the Location is Appropriate

WARNING! Do not store or use flammable materials, vapors, or liquids in the same location where this water heater is installed.

WARNING! To reduce the risk of carbon monoxide poisoning, install a fuel gas and carbon monoxide detector if the water heater is installed in a bathroom, bedroom, or any occupied room normally kept closed. Install and maintain the detector in accordance with the manufacturer's instructions and local codes.

Before installing your water heater, ensure that it will be located:

- Indoors in an area that will not freeze.
- In a location as close to a wall as practicable, as centralized with the water piping system as possible, and as close to the vent termination as possible.
- In a metal drain pan piped to an adequate floor drain or external to the building (Figure 27).
- In an area suitable for vertical installation.
- In an area with adequate space (clearances) for periodic servicing. There must be a minimum of 5-1/2 inches of front clearance, however, 24 inches of clearance is recommended.
- In an area that allows a minimum clearance from combustible surfaces as stated on page 10 of this manual and the "Flammable Vapors" label on the water heater.
- On a floor that can support the weight of a full water heater.

INSTALLATION

You will also want to follow these guidelines while considering an appropriate location:

- This water heater is not for use in manufactured (mobile) homes or outdoor installation.
- Do not install near air-moving devices such as exhaust fans, ventilation systems, or clothes dryers.
- Do not obtain ventilating air for the furnace/air handler from the same space as the water heater. Ensure that any return air ducts near the water heater are sealed.
- If the water heater is installed directly on carpeting, it shall be installed on a metal or wood panel extending beyond the full width and depth of the water heater by at least 3 inches in any direction. If the water heater is installed in an alcove or closet, the entire floor shall be covered by the aforesaid panel.
- If your area is prone to earthquakes, use special straps as required by local building codes.

NOTICE: The state of California requires bracing, anchoring, or strapping the water heater to avoid its moving during an earthquake. Contact local utilities for code requirements in your area, visit <http://www.dsa.dgs.ca.gov>, or call 1-916-445-8100 and request instructions. Other locations may have similar requirements. Check with your local and state authorities.

- Do not install in a location prone to physical damage by vehicles, flooding, or other risks.

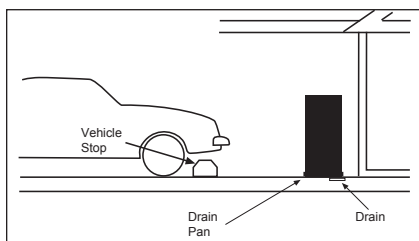

Figure 29 - In a garage, install a vehicle stop to avoid water heater damage.

- Avoid locations such as attics, upper floors, or where leaks might damage the structure or furnishings. Due to the normal corrosive action of water, the tank will eventually leak. To minimize property damage from leaks, inspect and maintain your water heater in accordance with this manual's instructions. Install a metal drain pan under the water heater piped to an adequate drain. Inspect the drain pan, pipes, and surrounding area regularly and fix any leaks found. Drain pans are available at your local plumbing supplier. Leaks are frequently in the plumbing system itself and not the water heater.

Step: 3

Removing the Old Water Heater

- 1 Read each installation step and decide if you have the necessary skills to install the water heater. Only proceed if you are comfortable you can safely perform the work. If you are not sure, have a qualified person perform the installation.
- 2 On the old water heater, turn the control knob on the gas control valve to the **OFF** position.

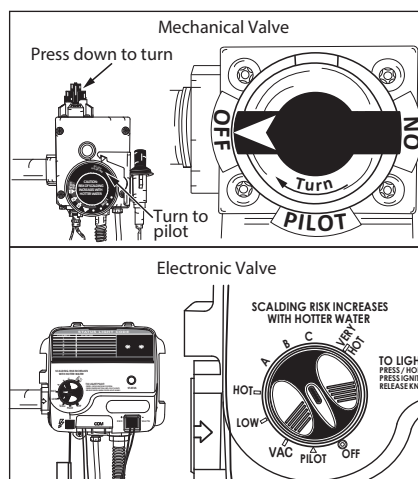

Figure 30 - Turn gas control/temperature knob OFF.

- 3 Turn the manual gas valve for the water heater's supply line **OFF**.
- 4 Open a hot water faucet and let the hot water run until it is cool.

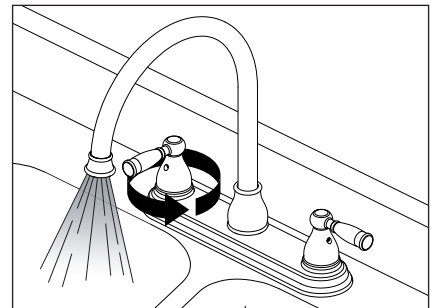

Figure 31 - Let the hot water run until it is cool.

▲ WARNING! Be sure the water runs cool before draining the tank to reduce the risk of scalding.

- 5 Connect a garden hose to the drain valve and place the other end of the hose in a drain, outside, or in buckets (sediment in the bottom of the tank may clog the valve and prevent it from draining. If you cannot get the tank to drain, contact a qualified person).
- 6 Turn the cold water supply valve **OFF**.

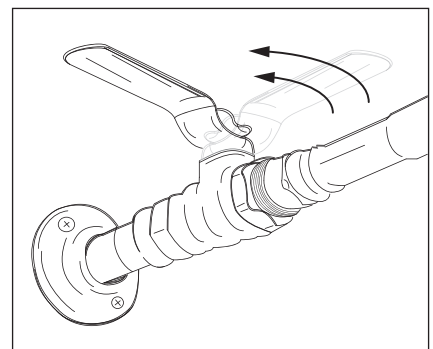

Figure 32 - Cold water supply in OFF position.

- 7 Open the drain valve on the water heater.

INSTALLATION

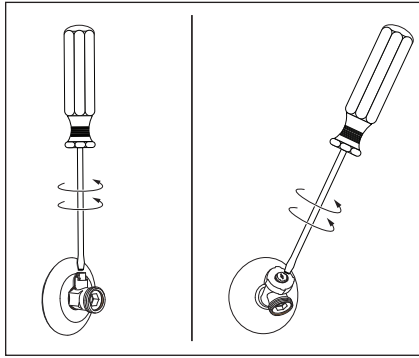

Figure 33 - Draining the old water heater.

- 8 Also open a hot water faucet to help the water in the tank drain faster.
- 9 When the tank is empty, disconnect the Temperature & Pressure (T&P) Relief Valve discharge pipe. You may be able to reuse the discharge pipe, but do not reuse the old T&P Relief Valve. A new T&P Relief Valve comes with your new water heater.

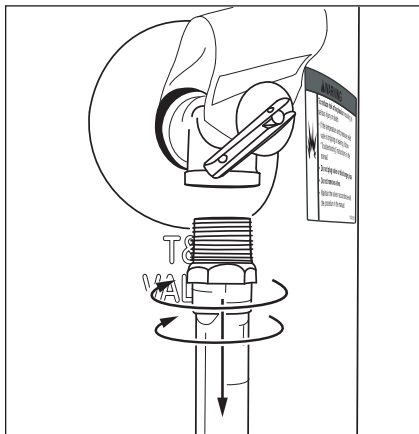

Figure 34 - Removing the T&P Relief Valve discharge pipe.

- 10 Allow the vent pipe and draft hood to cool. Once cooled, disconnect the vent pipe from the draft hood. You may need to support the vent pipe until the new water heater is in place.

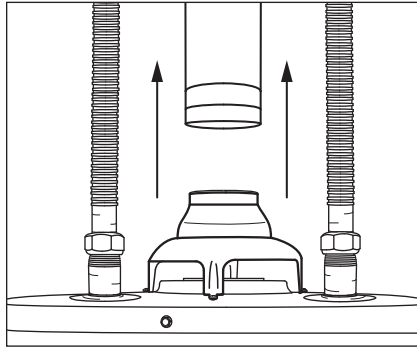

Figure 35 - Disconnect the vent pipe from the draft hood.

- 11 Disconnect the water pipes. Many water pipes are connected by a threaded union which can be disconnected with wrenches. If you must cut the water pipes, cut the pipes close to the water heater's inlet and outlet connections, leaving the water pipes as long as possible. If necessary, you can make them shorter later when you install the new water heater.
- 12 Confirm the manual gas valve for the water heater's supply line is turned **OFF**. Disconnect the gas line from the water heater's gas control valve and cap it.
- 13 Remove the old water heater. Use an appliance dolly or hand truck to move the water heater.

⚠ WARNING! Use two or more people to remove or install a water heater. Failure to do so can result in back or other injury.

Step: 4

Installing the New Water Heater

- 1 Completely read all instructions before beginning. If you are not sure you can safely complete the installation, seek assistance from any of the following sources:

- Schedule an appointment with a qualified person to install your water heater.
- Call our Technical Assistance Hotline which is listed on the water heater's warranty sheet.

- 2 Install a metal drain pan that is piped to an adequate drain.

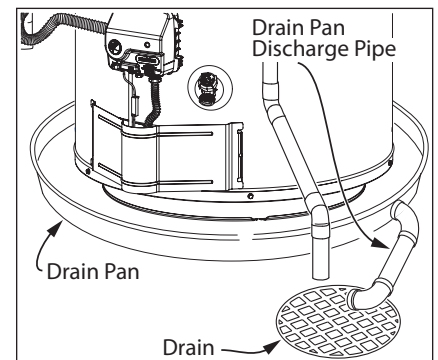

Figure 36 - Metal drain pan piped to an adequate drain.

- 3 Set the water heater in place taking care not to damage the drain pan. When installing directly on carpet, the water heater must be installed on a wood or metal base that extends beyond the dimensions of the water heater (width and depth) by at least 3 inches in any direction. If the water heater is installed on carpet in an alcove or closet, the entire floor must be covered by a wood or metal panel.

INSTALLATION

NOTICE: Most codes require setting the water heater in a metal drain pan piped to an adequate drain. The drain pan helps avoid property damage which may occur from condensation or leaks in the piping connections or tank. The drain pan must be at least 2 inches wider than the diameter of the water heater. Install the drain pan so the water level is limited to a maximum depth of 1- $\frac{3}{4}$ ".

4 Verify the water heater is properly set in place. Check that:

- There is adequate space to install the T&P Relief Valve discharge pipe and that it can be piped to a separate drain (and not into the drain pan, unless otherwise allowed by local and state codes).
- There is adequate access and space around the water heater for future maintenance.
- The water heater is installed vertically.

Step: 5

Connect the Temperature and Pressure (T&P) Relief Valve/Pipe

Most T&P Relief Valves are pre-installed at the factory. In some cases, they are shipped in the carton and must be installed in the opening marked "T&P Relief Valve" and according to local and state codes.

⚠ WARNING! To avoid serious injury or death from explosion, install a T&P Relief Valve according to the following instructions.

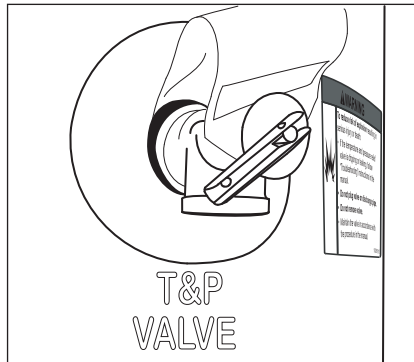

Figure 37 - Temperature and Pressure Relief Valve

If the T&P Relief Valve was not factory installed, install the new T&P Relief Valve that came with your water heater. Do not reuse an old T&P Relief Valve. Install a T&P Relief Valve discharge pipe according to local codes and the following guidelines:

- The discharge pipe should be at least $\frac{3}{4}$ " inside diameter and sloped for proper drainage. Install it to allow complete drainage of both the T&P Relief Valve and the discharge pipe.
- The discharge pipe must not be smaller than the pipe size of the T&P Relief Valve.
- The pipe must also be able to withstand 210°F without distortion. Use only copper or CPVC pipe approved for discharge use. Do not use any other type of pipe, such as PVC, iron, flexible plastic pipe, or any type of hose.

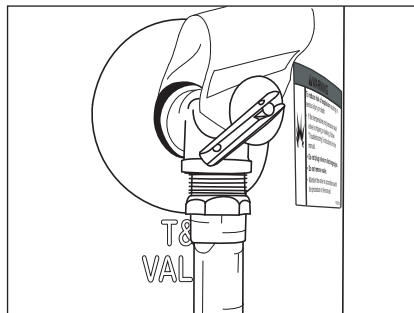

Figure 38 - The T&P Relief Valve discharge pipe must be installed properly and piped to an adequate drain.

- Terminate the discharge pipe a maximum of 6 inches above a floor drain or outside the building. Do not drain the discharge pipe into the drain pan; instead pipe it separately to an adequate drain. In cold climates, terminate the discharge pipe inside the building to an adequate drain. Outside drains could freeze and obstruct the drain line — protect the discharge pipe from freezing.

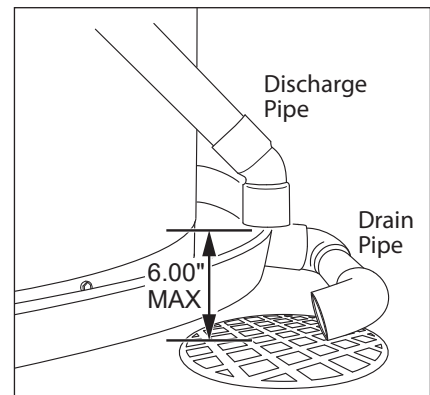

Figure 39 - Temperature and Pressure Relief Valve Discharge Pipe

- Do not place any valve or other restriction between the tank and T&P Relief Valve. Do not cap, block, plug, or insert any valve between the T&P Relief Valve and the end of the discharge pipe. Do not insert or install any reducer in the discharge pipe.

Step: 6

Install Shut-Off and Thermostatic Mixing Valves

- 1** Install a manual shut-off valve (available at your local plumbing supplier) on the cold water line that supplies the water heater. Install the shut-off valve near the water heater so that it is readily accessible. Only use valves that are compatible with potable water. Use only full-flow ball or gate valves. Other types of valves may cause excessive restriction to the water flow.

INSTALLATION

- 2 Install a Thermostatic Mixing Valve at each point-of-use (for example, kitchen sink, bathroom sink, bath, shower) per the valve manufacturer's instructions.

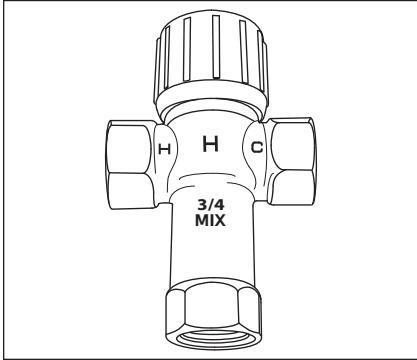

Figure 40 - Install Thermostatic Mixing Valves at each point-of-use.

⚠ WARNING! Even if the water heater's thermostat is set to a relatively low temperature, hot water can scald. Install Thermostatic Mixing Valves at each point-of-use to reduce the risk scalding.

- 3 For water heaters that are fed by a solar water heating system (or any other pre-heating system), always install a Thermostatic Mixing Valve or other temperature limiting device in the inlet water supply line to limit water supply inlet temperature to 120°F. Solar water heating systems can supply water with temperatures exceeding 180°F and may result in water heater malfunction.

⚠ WARNING! Hot water provided by solar heating systems can cause severe burns instantly, resulting in serious injury or death.

Step: 7

Connect the Water Supply

Note that all piping and components connected to the water heater must be suitable for use with potable water.

- 1 Determine the type of water pipes in your home. Most homes use copper water pipes (see following page), but some use CPVC or cross-linked polyethylene (PEX). Use fittings appropriate for the type of pipe in your home. Do not use iron or PVC pipe – they are not suitable for potable water.

The water inlet and outlet threaded connections are steel. When connecting the unit to piping made of a different material, use of a dielectric fitting or a dielectric union conforming to ASSE 1079 is recommended to prevent corrosion and potential subsequent water leaks at or near the connection. Dielectric fittings may be required by local plumbing codes.

IMPORTANT! A dielectric waterway nipple is different than a dielectric nipple and does not perform the same function. A dielectric waterway nipple will not protect the water heater from corrosion.

- 2 Connect the cold water supply using 3/4" National Pipe Thread ("NPT") to the cold water inlet nipple.

NOTICE: Most water heater models contain energy saving heat traps in the inlet and outlet connections. Do not remove the heat traps.

- 3 Connect the hot water supply using 3/4" NPT to the hot water outlet nipple.

- 4 Install insulation (or heat tape) on the water pipes especially if the indoor installation area is subject to freezing temperatures. Insulating the hot water pipes can increase energy efficiency.

- 5 Adjust (or install) the home's Pressure Reducing Valve to 50-60 psi and install a Thermal Expansion Tank.

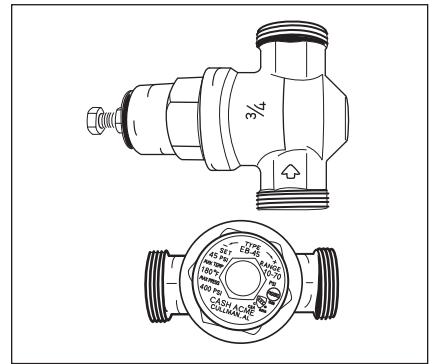

Figure 41 - A Pressure Reducing Valve is required if your home's water pressure is above 80 psi.

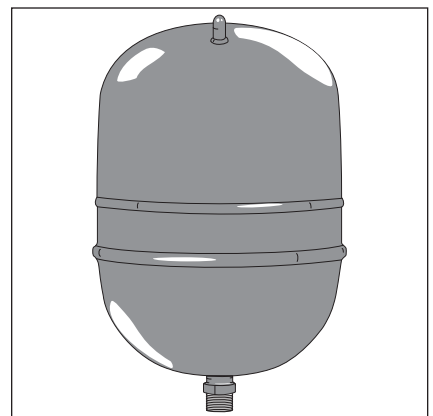
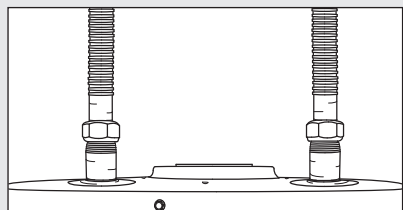

Figure 42 - The Thermal Expansion Tank should be pressurized with air to match the home's incoming water pressure.

INSTALLATION

IF YOU HAVE COPPER PIPES:

If your home has copper water pipes, you can solder the water pipe connections or use compression fittings which do not require soldering. Compression fittings are easier to install than soldering pipe. Check with local plumbing officials to determine what types of pipe materials are suitable for your location. Do not use lead-based solder.



Compression fittings don't require soldering.

NOTICE: Do not solder pipes while they are attached to the water heater. The water heater's inlet and outlet connections contain non-metallic parts which could be damaged. The proper way to connect the water heater to copper water pipes is as follows:

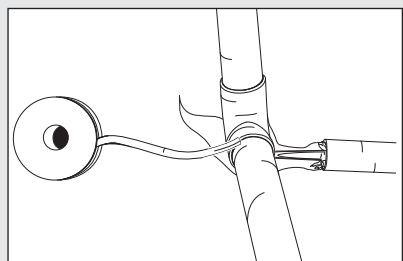

Solder a short length of pipe (about 12 inches) to a threaded adapter using only 95/5 tin-antimony or equivalent solder. Attach the threaded adapters to the water heater's connections (using thread sealant tape or pipe joint compound). Connect the home's water pipes by soldering, keeping the connections at the water heater cool with wet rags. **DO NOT** over apply joint compound.

Step: 8

Verify Connections and Completely Fill Tank

To remove air from the tank and allow the tank to fill completely with water, follow these steps:

1 Remove the flow restrictor at the nearest hot water faucet. This allows debris in the plumbing system to be washed out of the pipes.

2 Turn the cold water supply back on and fill the tank.

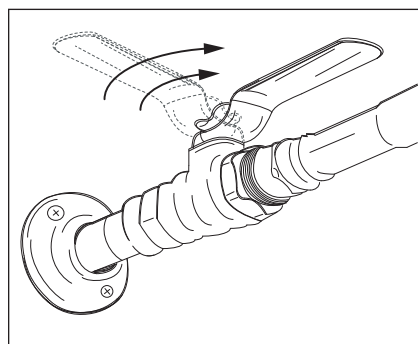

Figure 43 - Fully open the cold water supply valve.

3 Open a hot water faucet and allow the water to run until it flows with a full stream.

4 Let the water run full stream for three minutes.

5 Close the hot water faucet and replace the flow restrictor.

6 Check the inlet and outlet connections and water pipes for leaks. Dry pipe connections so that any drips or leaks will be apparent. Repair any leaks. Almost all leaks occur at connections and are not a tank leak.

Step: 9

Install New Vent Pipe

Install the new vent pipe on top of the water heater. Follow the "Venting" section on page 7.

Step: 10

Make Gas Connections

The Gas Water Heater Hook-Up Kit (available at your local plumbing supplier) includes a flexible gas connector with compression fittings to connect the home's gas line to the water heater's gas control valve. Follow the kit's installation instructions to attach the flexible gas connector.

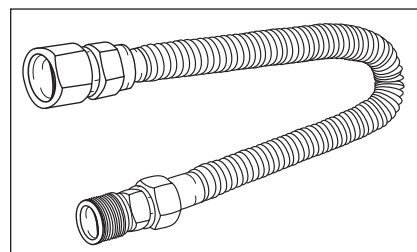

Figure 44 - Flexible Gas Line Connector

Once you have made the gas connections, use a small, soft-bristled brush to apply a hand dishwashing soap and water mixture or children's soap bubbles (1 part soap to 15 parts water) to all connection points of the gas line and flexible gas connector (if used). Make sure to generously coat all the connections and check for gas leaks (which will appear as small bubbles). If any leaks are detected, turn the gas supply off, tighten the leaking connections and re-check.

INSTALLATION

BEFORE LIGHTING THE WATER HEATER...

Make sure all checklist items have been completed.

Water Heater Location

- ✓ Centrally located with the water piping system. Located as close to gas piping and vent pipe system as possible.
- ✓ Installation area free of corrosive or flammable materials, liquids or vapors.
- ✓ Proper clearances from combustible surfaces maintained and sufficient room to service the water heater.
- ✓ Not installed directly on a carpeted floor.
- ✓ Metal drain pan installed and piped to an adequate drain.
- ✓ Located indoors and in a vertical position. Protected from freezing temperatures.

Vent Pipe System

- ✓ Vent system installed according to local and state codes or, in the absence of local and state codes, the "National Fuel Gas Code", ANSI Z223.1 (NFPA 54)-current edition.
- ✓ Evenly stretched out between water heater and vent termination hood.
- ✓ Smooth bends with adequate support to prevent sagging, 0.25" per foot.
- ✓ Inside pipe (3") and outside pipe (6") securely fastened to vent termination hood.

- ✓ Inside pipe (3") and outside pipe (6") securely fastened to water heater with silicone and gear clamps.

- ✓ Vent restrictor plate installed on heater flue outlet as applicable.

- ✓ Not obstructed in any way.

Vent Termination Hood

- ✓ Securely fastened to exterior wall.
- ✓ Above anticipated snow level or 12" above grade.
- ✓ Proper clearances from windows, doors, corners, other vent openings etc..
- ✓ Area around vent termination hood clear and unobstructed.

- ✓ No flammable vapor emitting products stored nearby.

- ✓ Safety covers in place (when applicable).

Water System Piping

- ✓ Temperature and Pressure Relief Valve properly installed with a discharge line run to an adequate drain and protected from freezing.

- ✓ Water pipes free of leaks.

- ✓ Water heater completely filled with water.

- ✓ Thermal Expansion Tank installed.

- ✓ Water Pressure Reducing Valve installed and properly adjusted to 50-60 psi.

- ✓ Thermostatic Mixing Valves installed at each point-of-use.

Gas Supply and Piping

- ✓ Gas type is the same as that listed on the water heater's data plate.

- ✓ Gas line equipped with shut-off valve, union and sediment trap.

- ✓ Adequate gas pipe size and approved gas pipe material.

- ✓ Approved pipe joint compound or tape used.

- ✓ All gas connections and fittings leak checked and any leaks corrected.

OPERATION

Lighting Instructions

▲ WARNING! Explosion Hazard — Replace viewport if glass is missing or damaged. Failure to do so can result in death, explosion or fire.

Read and understand these directions thoroughly before attempting to light or re-light the pilot. Make sure the viewport is not missing or damaged. Make sure the tank is completely filled with water before lighting the pilot. Check the data plate near the gas control valve to ensure the correct gas type. Do not use this water heater with any gas other than the one listed on the data plate. If you have any questions or doubts, consult your gas supplier or gas utility company.

NOTICE: A newly installed water heater will have air in the gas line. It may take several lighting attempts to clear all the air from the gas line and light the pilot.

Follow these steps to light the pilot:

- 1 Make sure the manual gas valve for the water heater's supply line is **ON**.

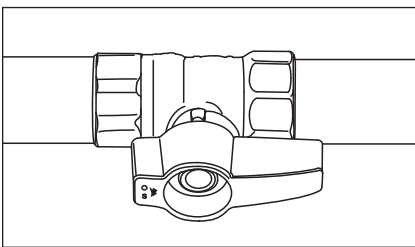

Figure 45 - Manual Gas Valve in ON position.

- 2 Turn the gas control knob to the **PILOT** position.
- 3 Press the gas control knob in fully and hold it in. While holding in the gas control knob, repeatedly click the igniter button (approximately once per second) for up to 90 seconds or until the Status Light starts to flash. You can tell the pilot is lit when the Status Light flashes once every three seconds.

- 4 Once the Status Light starts flashing, release the gas control knob. Adjust the gas control knob to the desired temperature setting.
- 5 If the Status Light doesn't start flashing after 90 seconds, release the gas control knob and wait 10 minutes.
- 6 Repeat lighting steps 2 through 5 at least two additional times or until the Status Light starts flashing once every three seconds. Wait 10 minutes between lighting attempts.
- 7 A solid Status Light means the pilot was lit but is now off. Release the gas control knob and wait 10 minutes. Once the Status Light goes out, repeat lighting steps 2 through 5.
- 8 If the Status Light doesn't start flashing after three lighting attempts, turn the gas control knob to the **OFF** position and refer to the "Troubleshooting - No Hot Water" section (see page 25).
- 9 When a gas water heater is first lit and the tank is cold, condensation often forms inside the water heater. You may hear drips or a sizzling sound when the water heater is first lit or, you may see a small puddle on the floor. Condensation is not a leak and will go away once the tank reaches normal operating temperature.

Shut Down Instructions

Turn the gas control/temperature knob counterclockwise to the "OFF" setting. The status light will stop blinking and stay on for a short time after the water heater is turned off.

Emergency Shut Down

This water heater is equipped with an automatic gas shut-off system. This system works when high water temperatures are present. Turn "OFF" the entire gas supply to the water heater. The high temperature shut-off is built into the gas control valve. It is non-resettable. If the high temperature shut-off activates, the gas control valve must be replaced. See "Removing and Replacing the Gas Control Valve/Thermostat" on page 32, or contact a qualified professional.

Should overheating occur or the gas supply fail to shut off, turn off the water heater's manual gas control valve and call a qualified person.

Check the Vent System and Air Supply

▲ WARNING! Burn Hazard. Do not touch the vent, doing so can cause burns.

Check for obstructions and/or deterioration of the vent piping, the intake air and vent terminations. The combustion and ventilation air flow must not be obstructed. Repair and/or replace immediately as necessary.

NOTICE: Do not reach inside the vent termination while the heater is in operation.

Remove any debris that may have accumulated on the screen in the vent termination.

Check all vent system connections for damage or deterioration which could cause improper venting or leakage of combustion products. Repair or reseal as necessary.

Be sure the vent piping is properly connected to prevent escape of dangerous flue gasses which could cause deadly asphyxiation.

OPERATION

Obstructions and deteriorated vent systems may present serious health risk or asphyxiation.

Chemical vapor corrosion of the flue and vent system may occur if air for combustion contains certain chemical vapors. Spray can propellants, cleaning solvents, refrigerator and air conditioner refrigerants, swimming pool chemicals, calcium and sodium chloride, waxes, bleach and process chemicals are typical compounds which are potentially corrosive.

If after inspection of the vent system you found sooting or deterioration, something is wrong. Call the local gas utility to correct the problem and clean or replace the flue and venting before resuming operation of the water heater.

Temperature Control System

Adjusting the Temperature

With the installation steps completed, you may adjust the water heater's temperature setting if desired.

1 Set the gas valve to the desired temperature. The "HOT" setting sets the water temperature to approximately 120°F, reducing the risk of scald injury. You may wish to set a higher temperature to provide hot water for automatic dishwashers or laundry machines, to provide more hot water capacity, and to reduce bacterial growth. Higher tank temperatures (140°F) kill bacteria that cause a condition known as "smelly water" and can reduce the levels of bacteria that cause water-borne diseases.

Water usage patterns, as well as heat from sources such as solar collectors, ambient air, and the pilot light can result in temperatures higher than the thermostat set-point.

▲ WARNING! Higher temperatures increase the risk of scalding, but even at 120°F, hot water can scald. Install Thermostatic Mixing Valve(s) at each point-of-use to reduce the risk of scalding.

2 To adjust the water heater's thermostat:

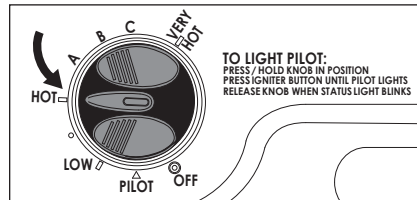

Figure 46 - Adjust the gas control knob to "HOT".

Turn the gas control knob on the gas control valve to the right to the following settings.

- "LOW" 91°F
- "HOT" 120°F
- "A" 130°F
- "B" 140°F
- "C" 150°F
- "VERY HOT" 155°F

NOTICE: The temperatures above are approximates. The actual temperature of the heated water may vary.

3 Wait for the water to heat up. If you have no hot water after two hours, refer to the Troubleshooting Section (see page 25).

NOTICE: If the tank is full of cold water, condensation may form inside the water heater. This condensation may drop on the burner causing a sizzling sound. In some cases, you may see a small puddle on the floor. Condensation is normal and should go away once the tank reaches its normal operating procedure.

▲ WARNING! If you have increased the temperature setting and the Thermostatic Mixing Valves are not set properly (or installed) you could scald yourself while checking the temperature.

4 Check water temperature at several points of use in your home (for example, bathtub faucet, shower, or lavatory sink) and adjust the Thermostatic Mixing Valves as needed. If you are not sure how to adjust the Thermostatic Mixing Valve settings, or are not sure if you have Thermostatic Mixing Valves, contact a qualified person.

Operating Modes

Standard Mode - The controller adjusts the water heater to maintain the temperature set by the user.

Vacation - The "LOW" position sets the controller at approximately 91°F. This setting is recommended for times when the water heater will not be in use for an extended period of time. It effectively turns the controller temperature setting down to a temperature that prevents the water in the water heater from freezing while still conserving energy.

TROUBLESHOOTING

Troubleshooting & Maintenance

If you are not qualified or are not comfortable performing any of the troubleshooting, repair or maintenance procedures that follow, call our Technical Assistance Hotline for further assistance, or contact a qualified person.

No Hot Water

Use the following step-by-step plan as a guide to help determine why you have no hot water:

1 Check the Status Light

The Status Light on the gas control valve flashes once every three seconds if the pilot is lit and the gas control valve has not detected any problems.

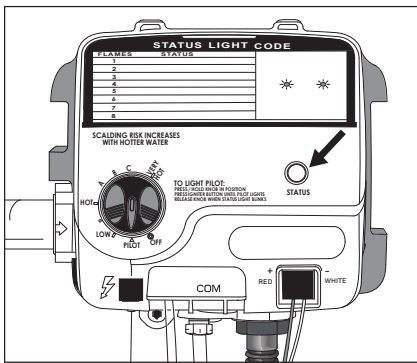

Figure 47 - Status Light

2 Status Light is Not Flashing

If the Status Light is flashing once every three seconds and you have no hot water, make sure the gas control knob is set to HOT.

If the Status Light flashes more than once every three seconds, refer to the Status Light Code Troubleshooting Chart on page 27.

If the Status Light is not flashing, go to step 3.

3 Checking the Pilot Light

Check the spark igniter. Dim the room lights and look through the viewport while clicking the igniter button.

If you don't see a spark through the viewport, check to make sure the igniter wire is firmly inserted into the white connector.

If you see a spark, make sure the gas supply valve is turned on, and try lighting the pilot using the lighting instructions on page 23.

If the pilot still does not light, call a qualified person.

Insufficient Hot Water or Slow Hot Water Recovery

⚠ WARNING! Because of the increased risk from scalding, if you set the water heater's gas control knob higher than 120°F, install Thermostatic Mixing Valves at each point-of-use. Due to the increased risk of scalding, DO NOT set the temperature of the Thermostatic Mixing Valves above 120°F.

If the hot water is simply not warm enough, there are several possible causes:

- Faulty Thermostatic Mixing Valve in a faucet or shower control (check other faucets in the house for hot water).
- Water heater's capacity too small (or usage too high).
- Reversed plumbing connections or melted dip tube (usually found soon after new installation).
- Plumbing leak.
- Sediment or lime buildup in the bottom of the tank.

Thermostatic Mixing Valves. If the hot water is simply not warm enough, make sure the faucet you are checking doesn't have a defective Thermostatic Mixing Valve. Many shower controls now have built-in mixing valves. If these devices fail, they can reduce the amount of hot water the shower or faucet delivers even though there is plenty of hot water in the tank. Always check the water temperature at several faucets to make sure the problem is not in a faucet or shower control.

Undersized Water Heater. If your water heater runs out of hot water quickly, it may be too small for your needs. If the water heater is old, consider replacing it with a larger model. If the water heater is in good condition, you may be able to meet your family's hot water needs with the existing water heater by installing Thermostatic Mixing Valves at each point-of-use and then turning the gas control knob to a higher setting.

You can also reduce your home's hot water needs by washing clothes in cold water, installing flow restrictors on shower heads, repairing leaky faucets, and taking other conservation steps.

Reversed Connections or Melted Dip Tube. Check the hot and cold water connections and make sure your home's hot water pipe is connected to the hot water outlet on the water heater. Usually, reversed connections are found soon after the installation of a new unit. If copper pipes were soldered while they were attached to the water heater, the dip tube may have melted. The dip tube is a long, plastic tube inside the tank attached to the cold water inlet. If the dip tube has melted, it can be replaced by removing the cold water inlet connection, removing the old dip tube and installing a new one.

TROUBLESHOOTING

Plumbing Leak. Even a small leak in the hot water side of the home's plumbing system can make it appear that the water heater is producing little to no hot water. In this case, the burner will be on all or almost all the time, yet you will have very little hot water. Locate and repair the leak.

Sediment or Lime in Tank. With an existing water heater, if you have some hot water but not as much as you are used to, there may be a build up of sediment or lime on the bottom of the tank. Sediment or lime buildup can reduce the efficiency of your water heater. Heavy deposits can damage the water heater. See the Maintenance section for steps on draining and flushing the water heater.

Temperature Too High

Adjust the gas control valve/thermostat on the water heater to a lower setting. Install or adjust Thermostatic Mixing Valves at each point-of-use (see the valve manufacturer's instructions).

Low Water Pressure

Check both the cold and hot water at a sink to determine if the lower pressure is only on the hot water side. If both hot and cold faucets have low pressure, call your local water utility. If the low pressure is only on the hot water side, the primary causes are:

- Melted heat traps or dip tube. Soldering copper pipes while they are connected to the water heater can melt the heat traps inside the hot and cold water connections or the dip tube (cold water side). Melted heat traps or a melted dip tube can restrict the flow of hot water. If that is the case, replace the heat traps or dip tube.
- Partially closed supply valve. Open the water heater's supply valve fully.

Drips from T&P Relief Valve Discharge Pipe

A small amount of water dripping from the Temperature and Pressure (T&P) Relief Valve usually means the home's water pressure is too high and/or you need a Thermal Expansion Tank. See Step 1 in the Installation section on page 15 of this manual for more information.

A large amount of hot water coming from the T&P discharge pipe may be due to the tank overheating. If the T&P Relief Valve is discharging large amounts of very hot water, turn the gas supply valve off and call a qualified person.

▲ WARNING! Do not cap or plug the T&P Relief Valve or discharge pipe, and do not operate the water heater without a functioning T&P Relief Valve — this could cause an explosion.

Water Pressure Too High. High water pressure can cause the T&P Relief Valve to drip. Install a Pressure Reducing Valve (PRV) on the main cold water supply line. Adjust the PRV to between 50 and 60 psi.

Thermal Expansion Tank. Install a Thermal Expansion Tank. If a Thermal Expansion Tank is already installed and the T&P Relief Valve discharge pipe drips, the home's water pressure may be too high or the Thermal Expansion Tank may be defective. Refer to the instructions that came with the Thermal Expansion Tank for more information.

Debris. In rare cases, debris can stick inside the T&P Relief Valve preventing the valve from seating fully. In that case, the T&P Relief Valve discharge pipe will drip. You may be able to clear debris from the T&P Relief Valve by manually operating the valve, allowing small quantities of water to

flush out the debris. Refer to the T&P Relief Valve Maintenance section of this manual.

▲ WARNING! When manually operating the Temperature Pressure Relief Valve, make sure that no one is in front of or around the discharge outlet. The water may be extremely hot and could cause severe burns. Also ensure that the water discharge will not cause property damage.

If the water pressure is between 50 and 60 psi, a Thermal Expansion Tank is installed and properly pressurized, and the valve has been cleared of any debris, and it still drips, the valve may be broken — have a qualified person replace the T&P Relief Valve.

Water Odor

Harmless bacteria normally present in tap water can multiply in water heaters and give off a "rotten egg" smell. Although eliminating the bacteria that causes "smelly water" is the only sure treatment, in some cases, the standard anode rod that came with your water heater can be replaced with a special zinc anode rod which may help reduce or eliminate the odor. Contact a qualified person.

NOTICE: To protect the tank, an anode rod must be installed in the water heater at all times or the warranty is void.

In cases where the "rotten egg" smell is very strong, you could increase the tank temperature to 140°F in order to reduce the bacterial growth in the tank.

▲ WARNING! Because higher temperatures increase the risk of scalding, if you set the thermostat(s) higher than 120°F, Thermostatic Mixing Valves at each point-of-use are particularly important.

TROUBLESHOOTING

Status Light and Diagnostic Code Troubleshooting Chart

LED STATUS OR ERROR CODE	INDICATES	CORRECTIVE ACTION
0 FLASHES (LED NOT LIT)	Pilot light is not lit or thermopile has not yet reached normal operating temperature.	Turn Gas Control Valve/Thermostat knob to "OFF". Wait 10 minutes, then attempt to relight Pilot by following the lighting instructions on the water heater's label. Until the thermopile reaches its normal operating temperature, the Status Light will not blink, even if the Pilot is lit. It may take up to 90 seconds of continuous Pilot operation before the thermopile reaches normal operating temperature and the Status Light starts to blink. If the Status Light does not blink after three lighting attempts, check to make sure unit is getting gas. Remove the outer door. Press reset button. Replace outer door. Turn Gas Control Valve/Thermostat knob to "OFF". Wait 10 minutes, then attempt to light Pilot by following the lighting instructions on the water heater's label. Look through the view port for the Pilot flame. If Pilot is not visible, the spark igniter or gas supply to the Pilot should be checked. If the Pilot is visible and the Status Light does not blink after 90 seconds of continuous Pilot operation, the Pilot flame may not be heating the thermopile sufficiently (weak Pilot), the thermopile may be defective, or wiring connectors may be loose.
RED LIGHT ON (SOLID)	Pilot light was recently extinguished and the thermopile is cooling down.	Turn Gas Control Valve/Thermostat knob to "OFF". Wait 10 minutes for the thermopile to cool, then attempt to relight Pilot by following the lighting instructions on the water heater's label. NOTE: This gas control valve/thermostat has built-in circuitry that requires waiting 10 minutes between lighting attempts. Until the thermopile reaches its normal operating temperature, the Status Light will not blink, even if the Pilot is lit. It may take up to 90 seconds of continuous Pilot operation before the thermopile reaches normal operating temperature and the Status Light starts to blink.
1 FLASH (EVERY 3 SECONDS)	Normal Operation	No corrective action necessary.
2 FLASHES	Pilot is lit but the thermopile is not producing the required output voltage.	Turn Gas Control Valve/Thermostat knob to "OFF". The thermopile is probably defective, but loose wiring connections or a weak Pilot flame can also cause this symptom.
4 FLASHES	The Gas Control Valve's temperature sensor has detected that the water temperature was too high. Once this condition occurs, the Main Burner and the Pilot Light will be shut off. Since the Pilot light will be off, should this condition occur, this Flash Code will only be displayed immediately after the Pilot has been relit. Turn Gas Control Valve/Thermostat knob to "OFF".	Relight pilot and verify 4 flashes. If 4 flashes are observed, turn Gas Control Valve/Thermostat knob to "OFF". Turn Main Gas Supply "OFF." Replace the Gas Control Valve/Thermostat. See "Removing and Replacing the Gas Control Valve/Thermostat" (page 32).
5 FLASHES	The temperature sensor (thermistor) is defective.	Turn Gas Control Valve/Thermostat knob to "OFF". Replace the temperature sensor (thermistor).
7 FLASHES	Gas Control Valve failure.	Turn Gas Control Valve/Thermostat knob to "OFF". Turn Main Gas Supply "OFF". Replace the Gas Control Valve/Thermostat. See "Removing and Replacing the Gas Control Valve/Thermostat" (page 32).

TROUBLESHOOTING

LED STATUS OR ERROR CODE	INDICATES	CORRECTIVE ACTION
8 FLASHES	<p>This condition only appears if the gas control/temperature knob has been turned off and the thermopile continued to produce electric power. This condition can occur if the thermopile does not cool down as quickly as expected when the unit is shut off. This condition can also occur if the gas control/temperature knob has been turned off and the pilot continues to operate because the pilot valve is stuck in the open position.</p>	<p>Make sure that the gas control valve/thermostat knob is set to "OFF". Wait one minute. Remove the outer door. Look through the sight glass for a pilot flame. If a pilot flame is observed with the gas control valve/thermostat knob set to the "OFF" position, the pilot valve is stuck open. Turn the main gas supply "OFF". Replace the gas control valve/thermostat. See "Removing and Replacing the Gas Control Valve/Thermostat" (page 32).</p> <p>If the pilot flame is not observed when the gas control valve/thermostat knob is set to the "OFF" position, wait 10 minutes for the thermopile to cool, then attempt to relight the pilot by following the lighting instructions on the water heater's label. If this condition returns, replace the gas control valve/thermostat. See "Removing and Replacing the Gas Control Valve/Thermostat" (page 32).</p>

MAINTENANCE

Routine Maintenance

Routine maintenance will help your water heater last longer and work better. If you cannot perform these routine maintenance tasks yourself, contact a qualified person.

IMPORTANT! Failure to perform required or recommended maintenance as described in the following sections may void the warranty.

Water Heater Maintenance

After the first six months, drain and flush the water heater and inspect the anode rod. Depending on the hardness of your water, repeat this process at least annually, or more frequently if needed.

Draining and Flushing the Water Heater

Tap water contains minerals that can form lime deposits or sediment in the bottom of the tank. The amount of lime deposits or sediment depends on the hardness of your tap water. The rate at which sediment builds up depends on water quality and hardness in your area, the temperature settings, and other variables. We recommend draining and flushing the water heater after the first six months of operation to determine the amount of sediment buildup. Draining sediment extends the life of the tank and drain valve.

IMPORTANT! Failure to drain and flush the water heater of sediment can deteriorate the tank and drain valve and cause leaks resulting in property damage.

To Drain and Flush the Tank:

- 1 Turn the gas control knob on the gas control valve to the **OFF** position.

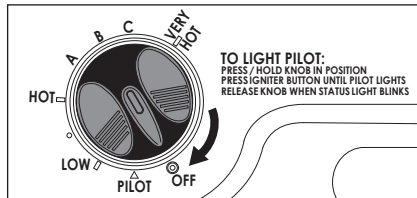

Figure 48 - Turn gas control/temperature knob OFF.

- 2 Turn the manual gas valve for the water heater's supply line **OFF**.
- 3 Open a hot water faucet and let the hot water run until it is cool.

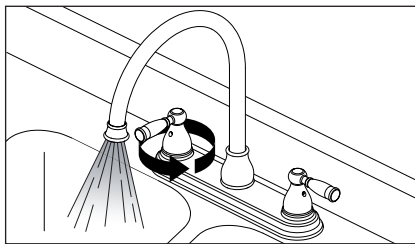

Figure 49 - Water Faucet.

▲ WARNING! Be sure the water runs cool before draining the tank to reduce the risk of scalding.

- 4 Connect a garden hose to the drain valve and place the other end of the hose in a drain, outside, or in buckets. Note that sediment in the bottom of the tank may clog the valve and prevent it from draining. If you cannot get the tank to drain, contact a qualified person.
- 5 Turn the cold water supply valve **OFF**.
- 6 Open the drain valve on the water heater.

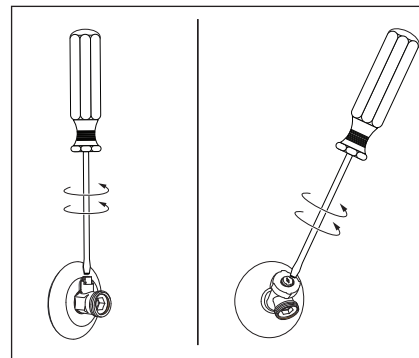

Figure 50 - Draining the water heater.

- 7 Open a hot water faucet to help the water in the tank drain faster.
NOTICE: DO NOT attempt to light the water heater unless the tank is completely full of water. For complete instructions on filling the tank, follow Step 8 on page 21.
- 8 If a large amount of sediment was present when the tank was drained, flush the tank by opening the cold water supply valve and letting the water run until no more sediment drains from the tank. Close the drain valve when you are done.
NOTICE: Inspect the anode rod after the first six months of operation when you drain and flush the tank. See the following section for instructions on how to inspect and replace the anode rod if necessary.
- 9 Refill the tank by opening the cold water supply valve. Make sure a hot water faucet is open and the drain valve is closed. Allow a hot water faucet to run full for at least three minutes to make sure the tank has all the air removed and is completely full of water. Once you are certain the tank is completely full of water, close the hot water faucet.

MAINTENANCE

10 Relight the pilot using the instructions on page 23 and adjust the gas control knob to the desired temperature. It may take an hour or more for the tank of cold water to heat up.

Replacing the Anode Rod

Anode Rod. The anode rod is a sacrificial metal rod and is the water heater's first line of defense to prevent corrosion and premature failure (leaks) in the tank. The anode rod is a consumable item. Inspect the anode rod after the first six months of operation when you drain and flush the tank. Replace the anode rod if it is substantially worn out or depleted. Thereafter, inspect the anode rod annually or more frequently if needed. If you use a water softener, your anode rod will deplete faster than normal. Inspect the anode rod more frequently, replacing the anode rod as needed. Obtain a new anode rod from your local plumbing supplier or have a qualified person replace it. (Anode rods are a consumable item and are not covered under warranty).

1 Remove and inspect the anode rod (see the Repair Parts List on page 33 to locate the anode rod). Replace the anode rod if it is depleted. Turn power **OFF**. Run hot water until it is cool. Turn cold water supply valve **OFF**. Open a hot water faucet to depressurize tank. Locate and remove the black plastic cover marked "Anode." Use a "key hole" saw or similar tool to remove the foam insulation covering the anode rod. Remove the anode rod by using an impact wrench rated at 1400 ft-lb breakaway torque and fitted with a 6 point – 1-1/16" socket turning counterclockwise. Ensure socket is seated completely on the anode head before attempting removal to avoid stripping the anode head. Inspect the anode rod and replace if depleted.

2 Apply thread sealant tape or pipe joint compound and reinstall the anode rod tightly using a 1-1/16" socket wrench with an extension. It is not necessary to replace the foam removed to access the anode. Turn cold water supply valve **ON**. When hot water runs full, close hot water faucet. Check for leaks and repair if necessary. Turn power **ON**.

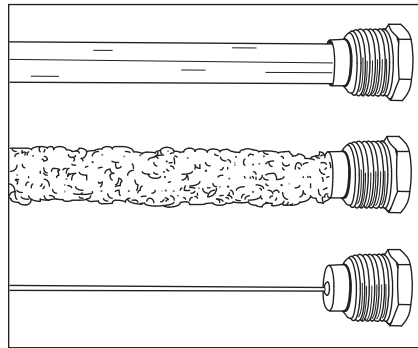

Figure 51 - Anode rods from new (top) to partially depleted (middle) to fully depleted stage (bottom).

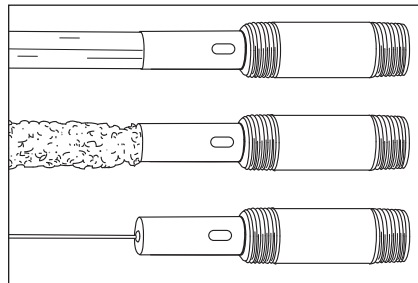

Figure 52 - Combination heat trap nipple/anode rods from new (top) to partially depleted (middle) to fully depleted stage (bottom).

NOTICE: If equipped, the combination heat trap nipple/anode rod (see Figure 52) will be located at the hot water outlet side of the unit. Use a pipe wrench at the nipple to remove and replace the combination heat trap/nipple anode rod. When removing or replacing the anode rod, use caution and **DO NOT** damage the nipple threads. If you can not perform this task yourself, contact a qualified person.

Visual Inspection

On an annual basis, visually inspect the venting and air supply system, piping systems, main burner, and pilot burner.

If you lack the necessary skills required to properly perform this visual inspection or if the burner needs to be cleaned, get help from a qualified person.

Check the water heater for the following:

- Obstructions, damage, or deterioration in the venting system. Make sure the ventilation and combustion air supplies are not obstructed.
- Buildup of soot and carbon on the main burner and pilot burner. The burner may be cleaned with soap and hot water.
- Inspect the burner flames through the viewport and compare them to the drawing below. A properly operating burner should produce a soft blue flame. Blue tips with yellow inner cones are satisfactory. The tips of the flame may have a slight yellow tint. The flame should not be all yellow or have a sharp blue-orange color. Contaminated air may cause an orange colored flame. Contact a qualified technician if the flame is not satisfactory.

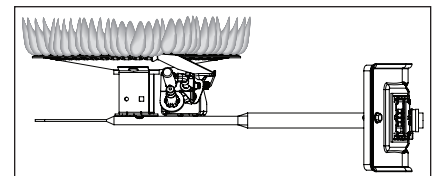

Figure 53 - Burner Flames

- After several minutes, the burner screen may glow red. If large flames are observed at any time, shut off the unit and call a qualified person.

MAINTENANCE

- Leaking or damaged water and gas piping.
- Remove any flammable, corrosive or combustible materials near the water heater.

T&P Relief Valve Maintenance

Read and follow the operating and annual maintenance instructions provided by the manufacturer of the T&P Relief Valve (yellow label attached to T&P Relief Valve). If no label is attached to the T&P Relief Valve, follow the instructions in this section.

Minerals in the water can form deposits that cause the valve to stick or create blocked passages, making the T&P Relief Valve inoperative. Follow these guidelines:

- At least annually, inspect the T&P Relief Valve and discharge pipe for damage caused by corrosive water conditions and mineral deposits. Operate the T&P Relief Valve manually to ensure the waterways are clear and the valve mechanism moves freely (see Figure 54). Before operating the valve manually, check that it will discharge in a place for secure disposal.
- After manually operating T&P Relief Valve, remove any water in the drain pan and wipe away any water from the heater.

⚠ WARNING! Hot water will be released. Before opening the T&P Relief Valve manually, check that it will discharge in a safe place. If water does not flow freely from the end of the discharge pipe, turn the power to the water heater OFF. Call a qualified person to determine the cause.

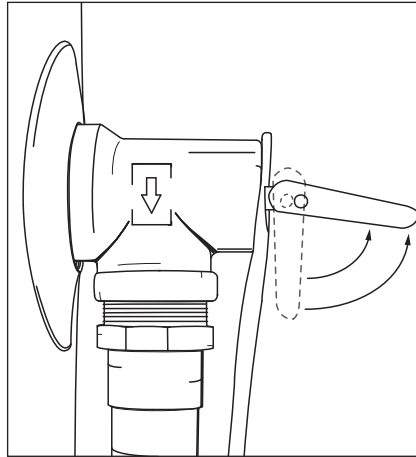

Figure 54 - T&P Relief Valve

Note that a dripping T&P Relief Valve is usually caused by the home's water pressure being too high and/or lack of a Thermal Expansion Tank. If your T&P Relief Valve drips, see page 26.

NOTICE: Expansion tanks are pre-charged with a minimum of 12 psi air charge. The expansion tank's air pressure must be adjusted to match the inlet pressure of your home but must not be higher than 80 psi.

A T&P Relief Valve that has been allowed to drip for an appreciable period of time should be inspected for mineral buildup.

MAINTENANCE

Removing and Replacing the Gas Control Valve

Removing the Gas Control Valve:

- 1 Turn the gas control/temperature knob to the "OFF" position.

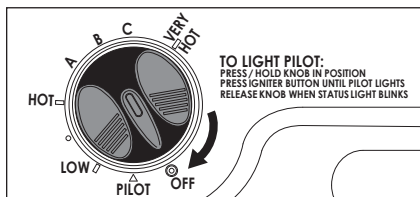

Figure 55 - Turn gas control/temperature knob OFF.

- 2 Turn off the gas at the manual shut-off valve on the gas supply pipe.

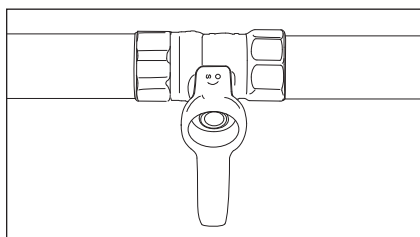

Figure 56 - Gas valve in "off" position.

- 3 Drain the water heater. Refer to the "Draining and Flushing the Water Heater" section (see page 29) and follow the procedure.

- 4 Disconnect the **A** igniter wire from the igniter lead wire. Use needle nose pliers to disconnect the **B** red (+) and white (-) thermopile wires. Disconnect **C** pilot tube (7/16" wrench) and **D** manifold tube (3/4" wrench) at the gas control valve/thermostat.

NOTICE: L.P. Gas systems use reverse (left-hand) threads on the manifold tube.

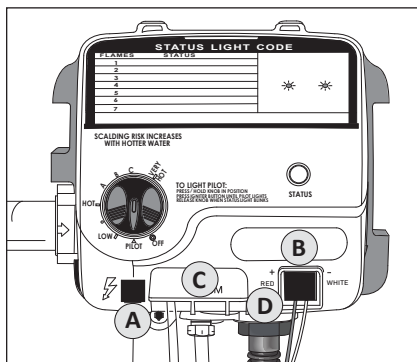

Figure 57 - Gas valve connections.

- 5 Disconnect the ground joint union in the gas piping. Disconnect the remaining pipe from the gas control valve/thermostat.

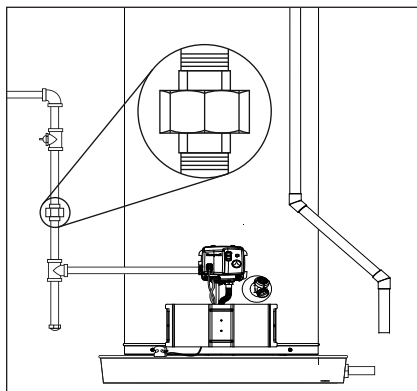

Figure 58 - Ground joint union connection.

- 6 To remove the gas control valve/thermostat, thread a 4" section of gas pipe into the inlet and use it to turn the gas control valve/thermostat (counterclockwise.) Do not use pipe wrench or equivalent to grip body. Damage may result, causing leaks. Do not insert any sharp objects into the inlet or outlet connections. Damage to the gas control valve/thermostat may result.

Replacing the Gas Control Valve:

To replace the gas control valve/thermostat, reassemble in reverse order. When replacing the gas control valve/thermostat, thread a 4" section of gas pipe into the inlet and use it to

turn the gas control valve/thermostat (clockwise.) DO NOT OVER TIGHTEN, damage may result.

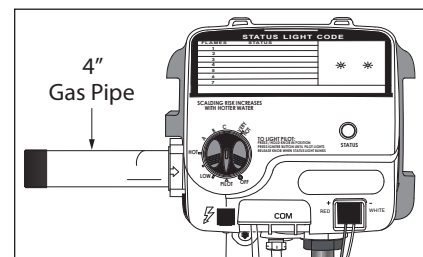

Figure 59 - Gas control valve with threaded pipe.

- Be sure to use approved thread sealant tape or pipe joint compound on the gas piping connections and fitting on the back of the gas control valve that screws into tank.
- Be sure to remove the pilot ferrule nut from the new gas control valve/thermostat.
- Turn the gas supply on and check for leaks. Test the water heater with the main burner on by brushing on an approved noncorrosive leak detection solution. Bubbles forming indicate a leak. Correct any leak found.

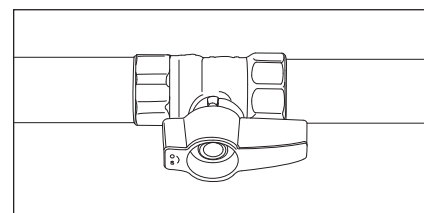

Figure 60 - Gas valve in "on" position.

- Be sure tank is completely filled with water before lighting and activating the water heater. Follow the "Lighting Instructions" on page 23.
- If additional information is required, contact our Technical Assistance Hotline which is listed on the water heater's warranty sheet.

REPAIR PARTS

Replacement parts may be ordered through your plumber, local distributor, home improvement center, or by calling our Technical Assistance Hotline which is listed on your warranty. When ordering parts, always give the following information:

1. Model, serial, and product number
2. Item number
3. Parts Description

Repair Parts List

Item No.	Parts Description
1	Vent Termination Hood
2	Wall Plate
3***	Vent Pipe
4	Cold Water Inlet Nipple/Diptube
5	Side Connect - Hot Outlet
6	T&P Valve
7	Gas Control Valve/Thermostat
8	Side Connect - Cold Inlet
9	Discharge Pipe
10	Drain Valve
11	Outer Gas Door
12**	Manifold Door Assembly (behind outer door)
13	Floor Drain
14	Metal Drain Pan
15	Flexible Manifold Tube
16	Sediment Trap
17	Ground Joint Union
18	Manual Gas Shut-off Valve
19	Gas Supply
20	Baffle Assembly
21	Rating Plate
22**	Anode Rod (Under Cap)
23	Hot Water Outlet
24	Inlet Water Shut-off Valve
25	Union (Water Connection)
26	Air Inlet Snorkel
27	Air Tower
28***	Airbox
29	Thermal Expansion Tank
30*	Sheet Metal Burner
31*	Gas Orifice
32*	Gas Manifold
33*	Manifold Door Gasket
34*	Manifold Door
35*	Two Piece Grommet with Clip
36*	Viewport
37*	Flexible Manifold Tube
38*	Pilot
39*	Thermopile
40*	Pilot Shield

* Pictured on next page.
 ** Items not shown.
 *** During operation the vent pipe and airbox can get hot.

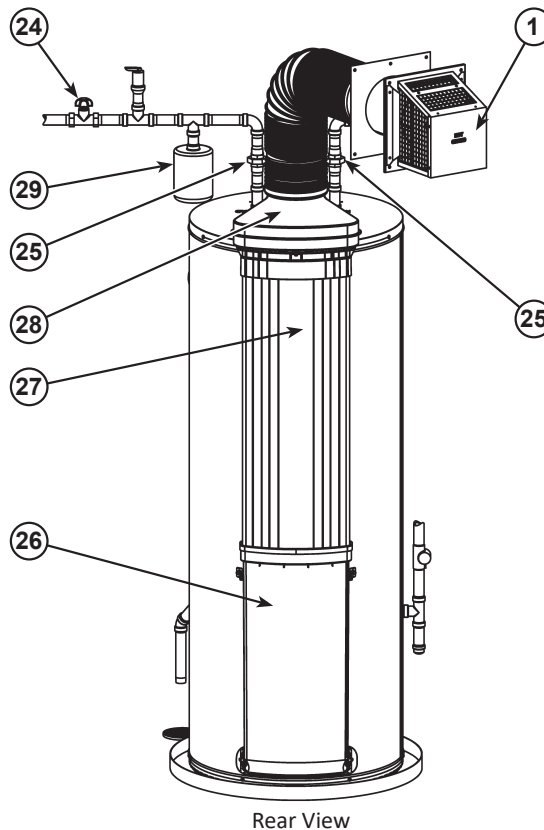
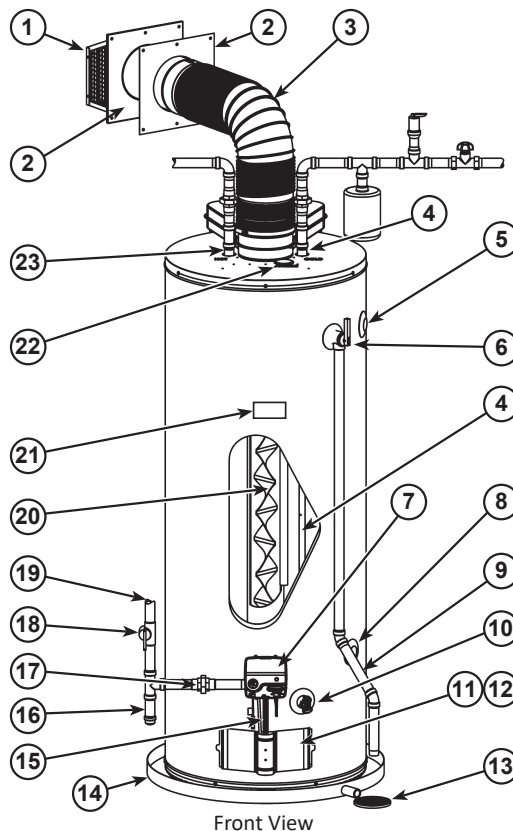

REPAIR PARTS

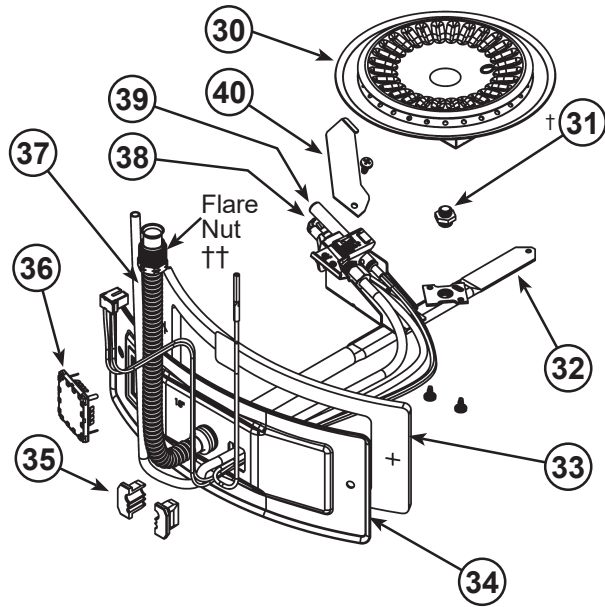

Natural gas and Propane (LP) main burner with igniter assembly for 38k to 42k Btu/hr models

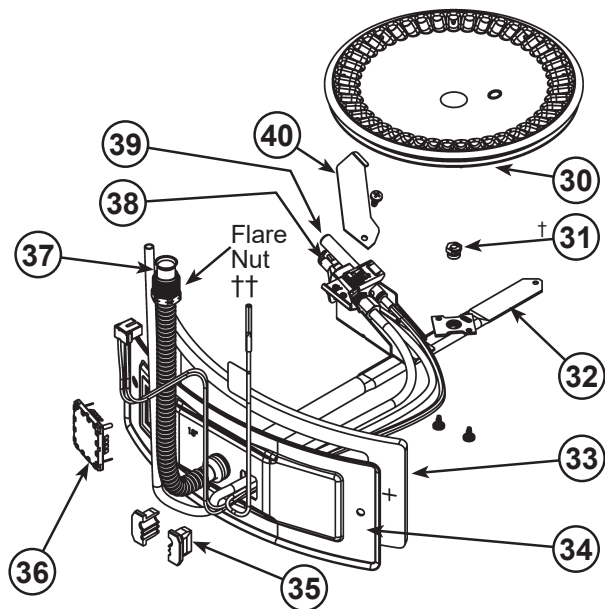

Natural gas and Propane (LP) main burner with igniter assembly for 47k Btu/hr models

NOTES:

- † The orifice on Natural gas models has Right-hand thread. The orifice on Propane (LP) models has Left-hand thread.
- †† For Natural gas models the Flare Nut has Right-hand thread. For Propane (LP) models the Flare Nut has Left-hand thread.

NOTES
